

CRANE 01B5SER_1000

LIFTING CAPACITY 500 KG
COUNTERBALANCED SWIVEL CRANE ELECTRIC LIFT/LOWER/EXTEND/RETRACT
THROUGH PUSH BUTTON REMOTE CONTROL



Model		01B5SER_1000
Drive		Manual
Rotation		360° manual - slewing bearing system
Arm lifting		Electric – remote control
Arm lowering		Electric – remote control
Arm extension		Electric – remote control
Width with arm not rotated	mm/inch.	980 / 38
Width with arm rotated at 90°	mm/inch.	1140 / 45
Max capacity with standard arm	Kg / lbs.	500 / 1102 * see load chart below
Max capacity with extension PZG_SE	Kg / lbs.	100 / 220 * see load chart below
Weight of the crane (counterweight incl.)	Kg / lbs.	680 / 1499
Battery type standard		Lead acid
Batteries nos.	pcs	1
Battery voltage / nominal capacity	V / Ah	12 / 80
Lifting motor	W	-
Traction motor	W	-

CRANE 01B5SER_1000 MAIN DIMENSIONS

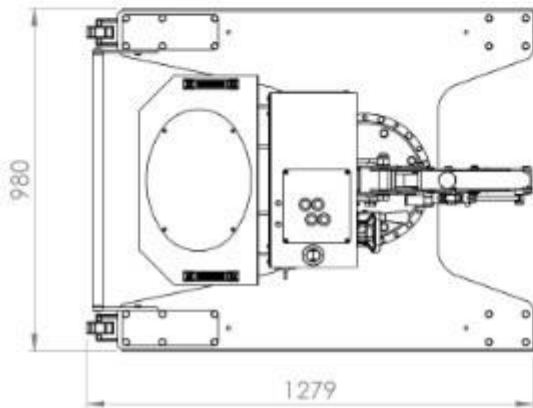
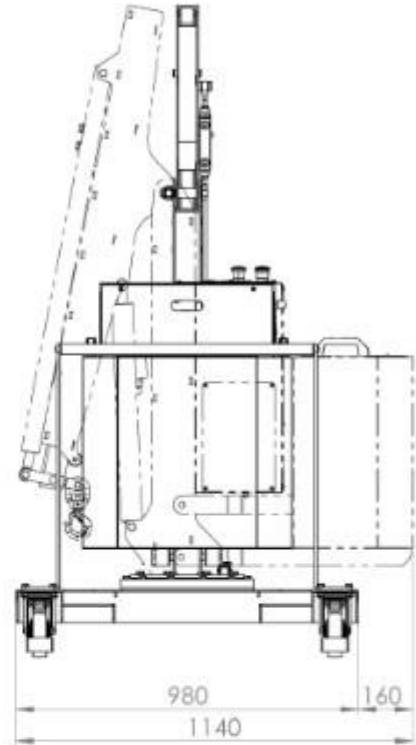
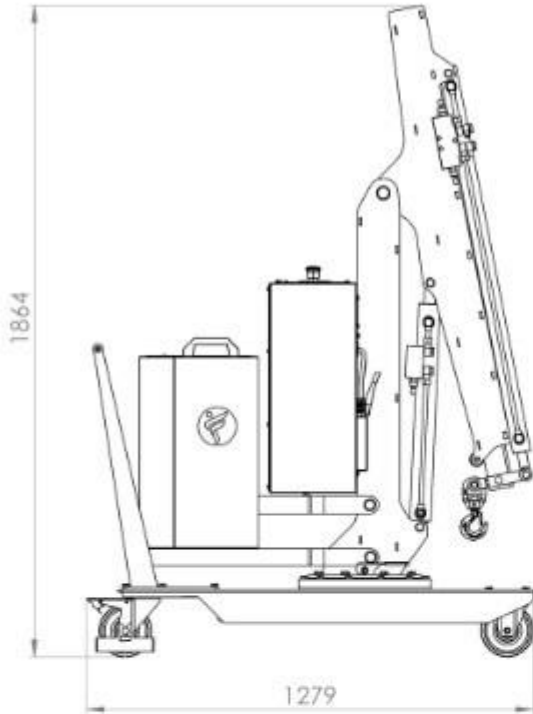

CRANE 01B5SER_1000 DETAILED DIMENSIONS WITH STANDARD ARM

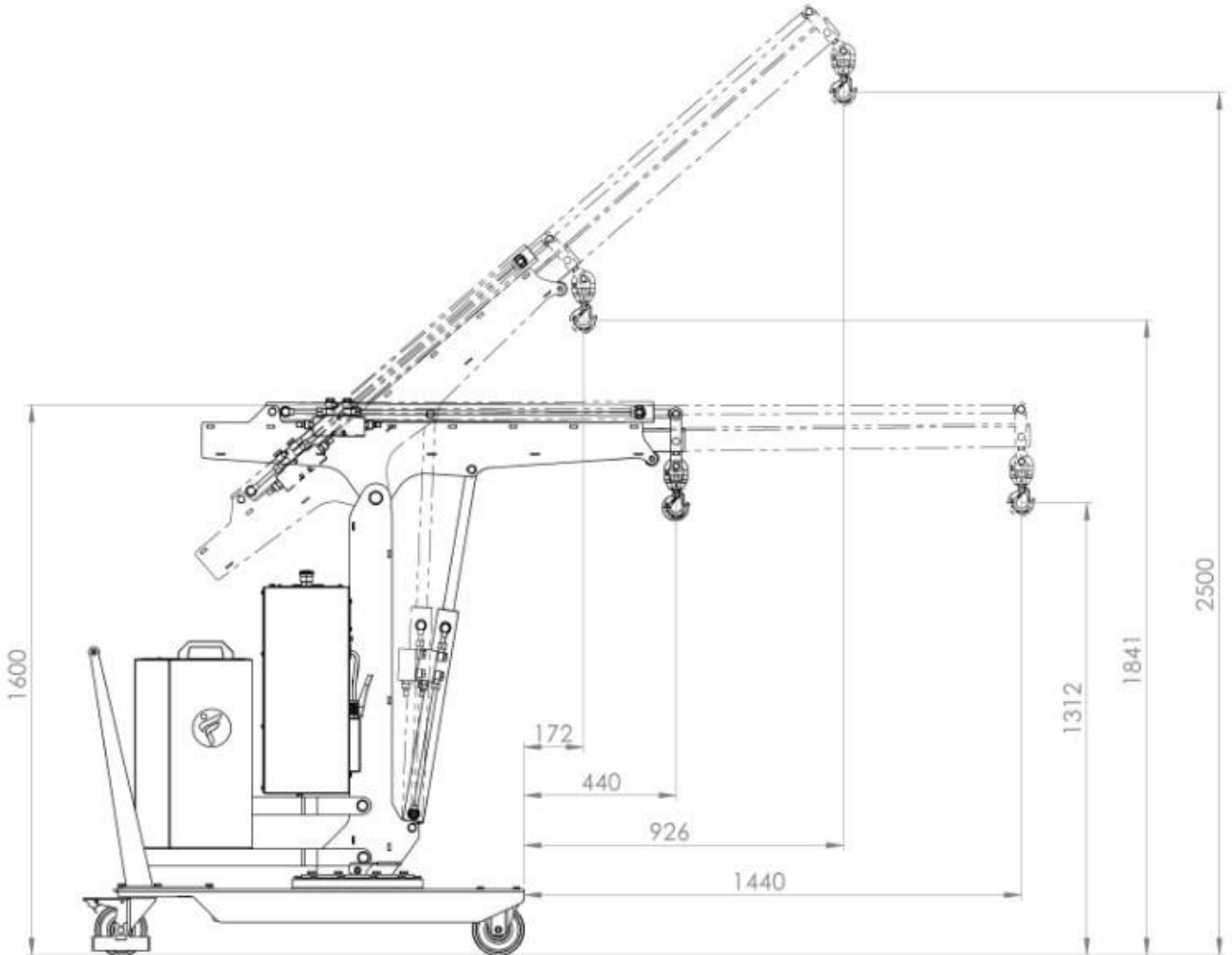

CRANE 01B5SER_1000 MAIN DIMENSIONS

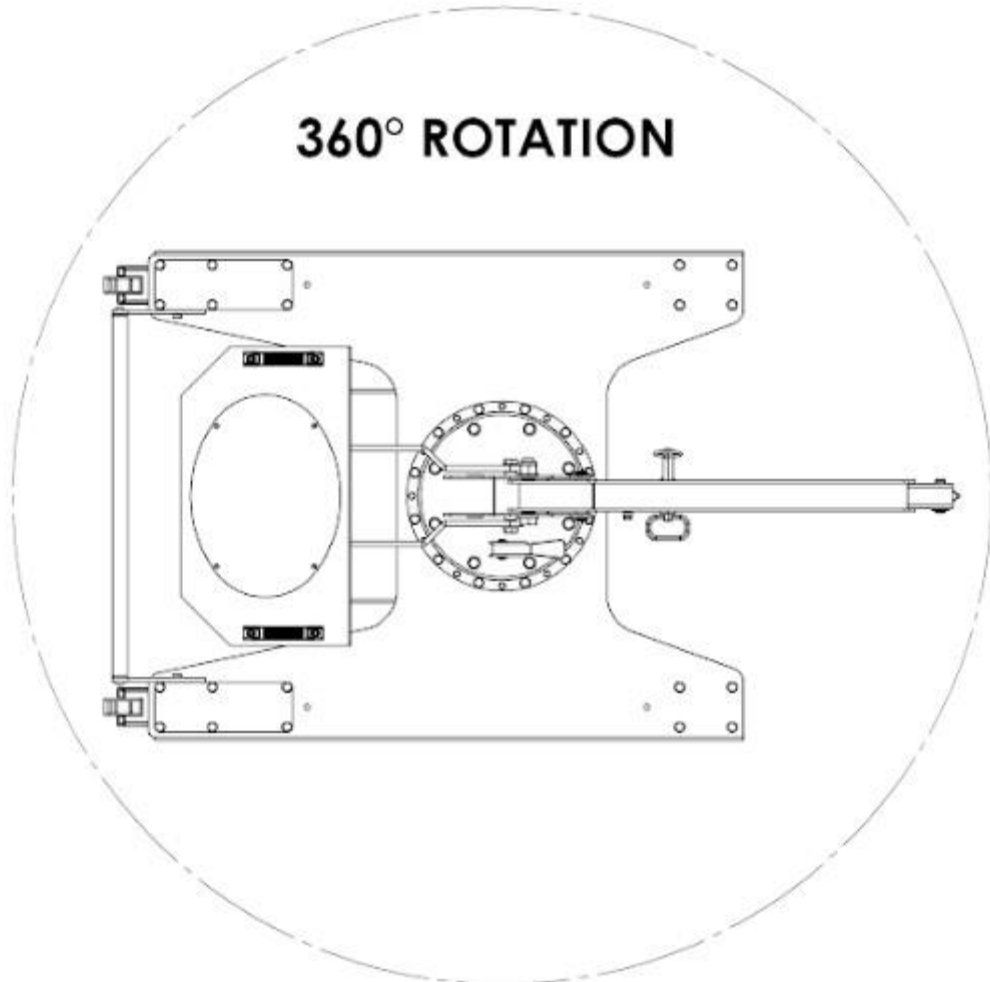

CRANE 01B5SER_1000 LOAD CHART WITH STANDARD ELECTRIC ARM

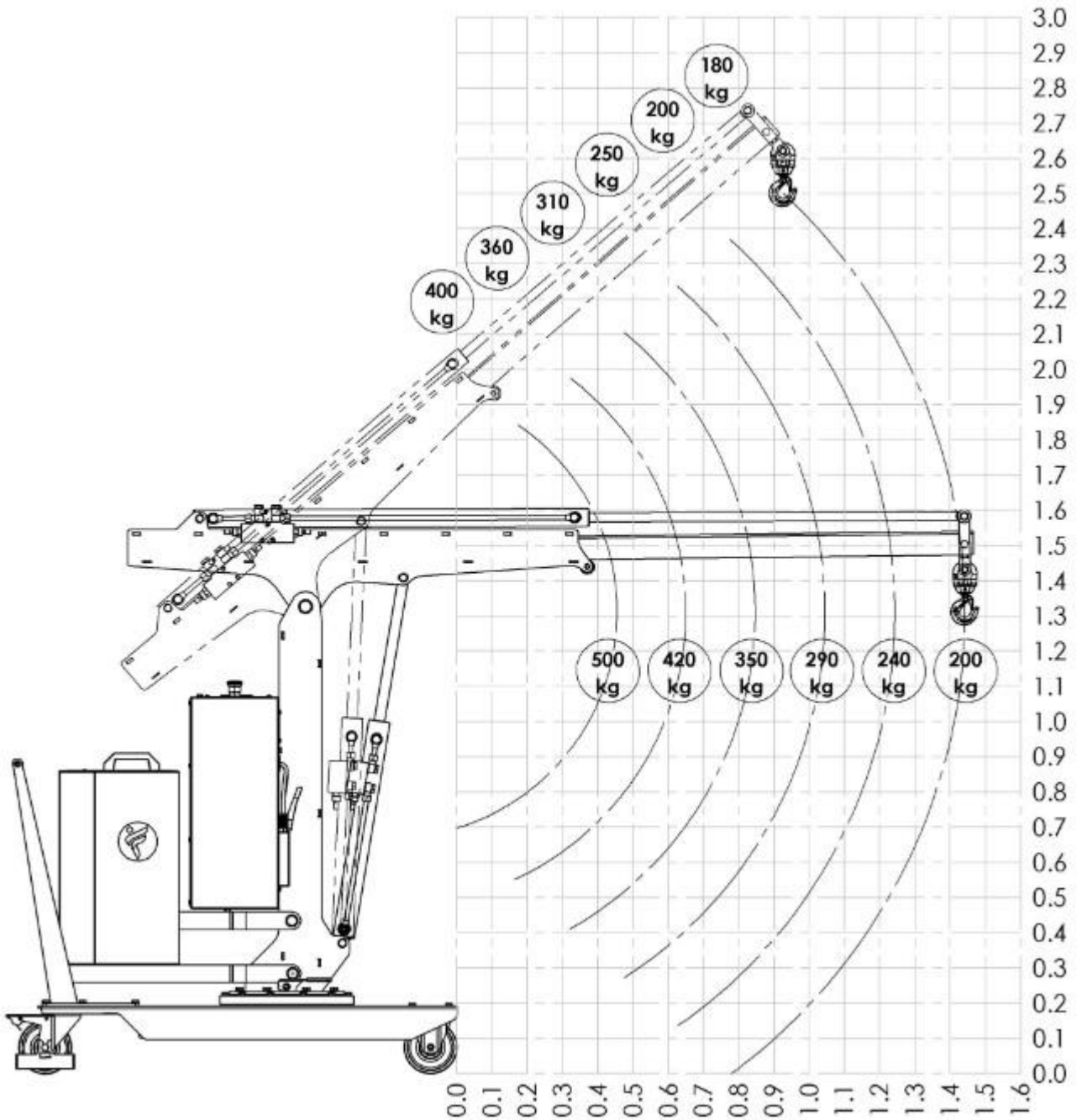

CRANE 01B5SER_1000

LOAD CHART WITH OPTIONAL MECHANICAL EXTENSION PZG_SE

