

## CRANE 01B5SE\_400

LIFTING CAPACITY 500 KG  
COUNTERBALANCED SWIVEL CRANE ELECTRIC LIFT/LOWER/EXTEND/RETRACT  
THROUGH 4 LEVER DISTRIBUTOR AT ADJUSTABLE SPEED



Model		01B5SE_400
Drive		Manual
Rotation		360° manual - slewing bearing system
Arm lifting		Electric – control lever
Arm lowering		Electric – control lever
Arm extension		Electric – control lever
Width with arm not rotated	mm/inch.	980 / 38
Width with arm rotated at 90°	mm/inch.	1140 / 45
Max capacity with standard arm	Kg / lbs.	500 / 1102 * see load chart below
Max capacity with extension PZG_SE	Kg / lbs.	160 / 352 * see load chart below
Weight of the crane (counterweight incl.)	Kg / lbs.	645 / 1421
Battery type standard		Lead acid
Batteries nos.	pcs	1
Battery voltage / nominal capacity	V / Ah	12 / 80
Lifting motor	W	-
Traction motor	W	-

## CRANE 01B5SE\_400 MAIN DIMENSIONS

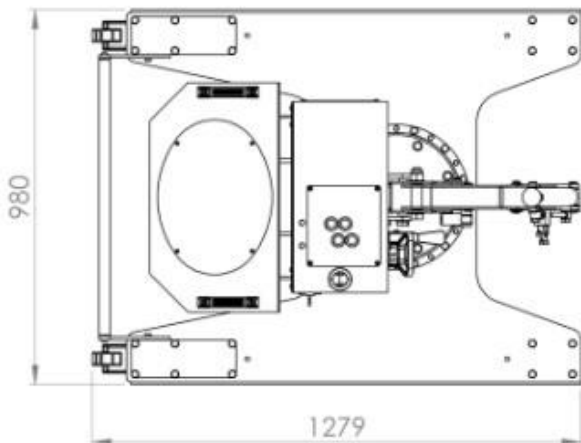
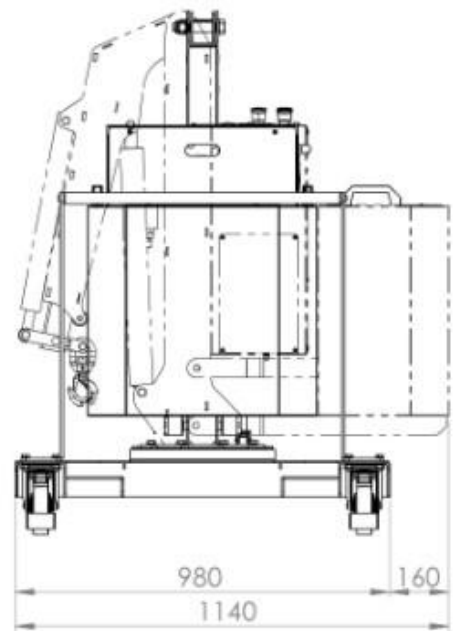
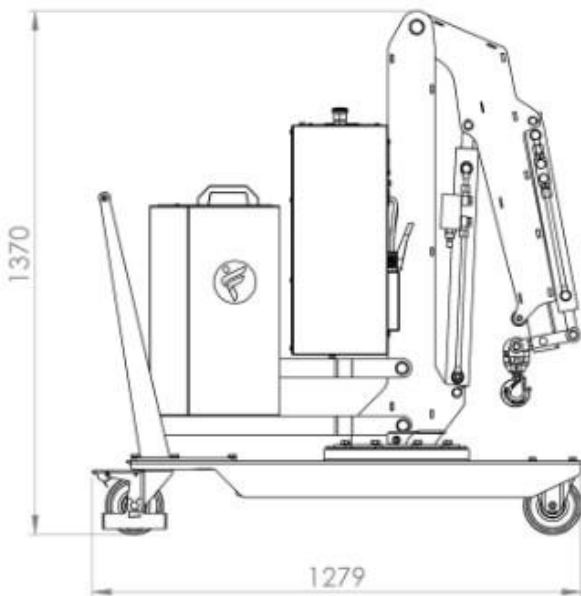

MAT.	FINITURA (FINISH)
SPESORE (THICKNESS) [mm]	PESO (WEIGHT) [kg]

## CRANE 01B5SE\_400 DETAILED DIMENSIONS WITH STANDARD ARM

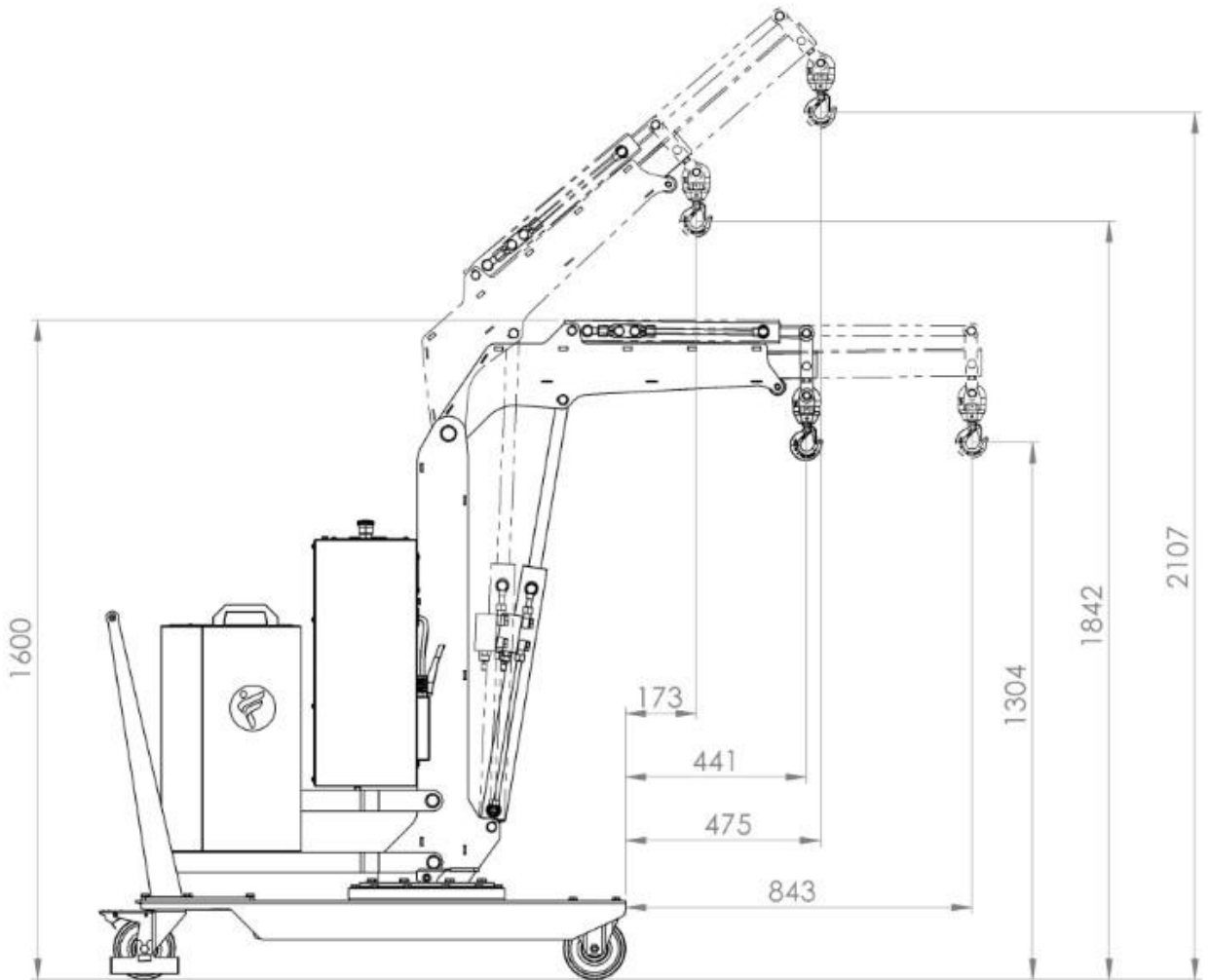

## CRANE 01B5SE\_400 MAIN DIMENSIONS

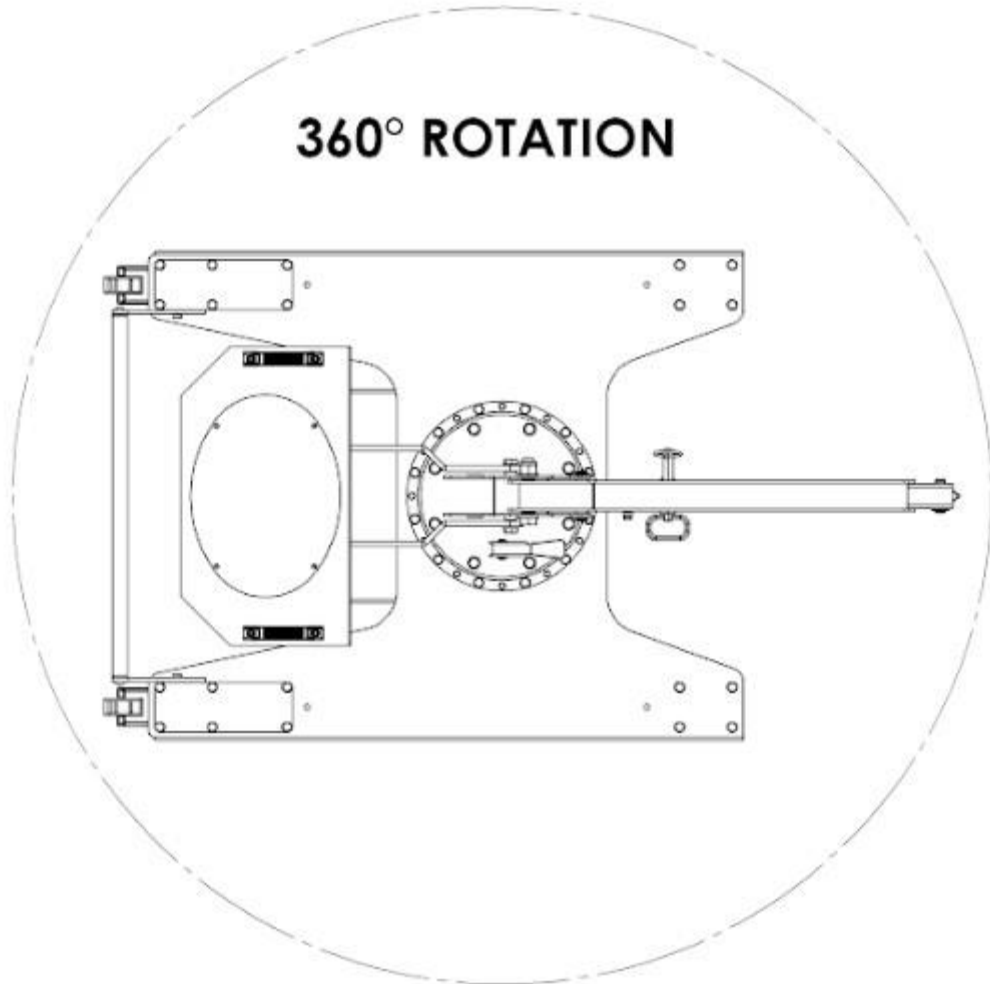

## CRANE 01B5SE\_400 LOAD CHART WITH STANDARD ELECTRIC ARM

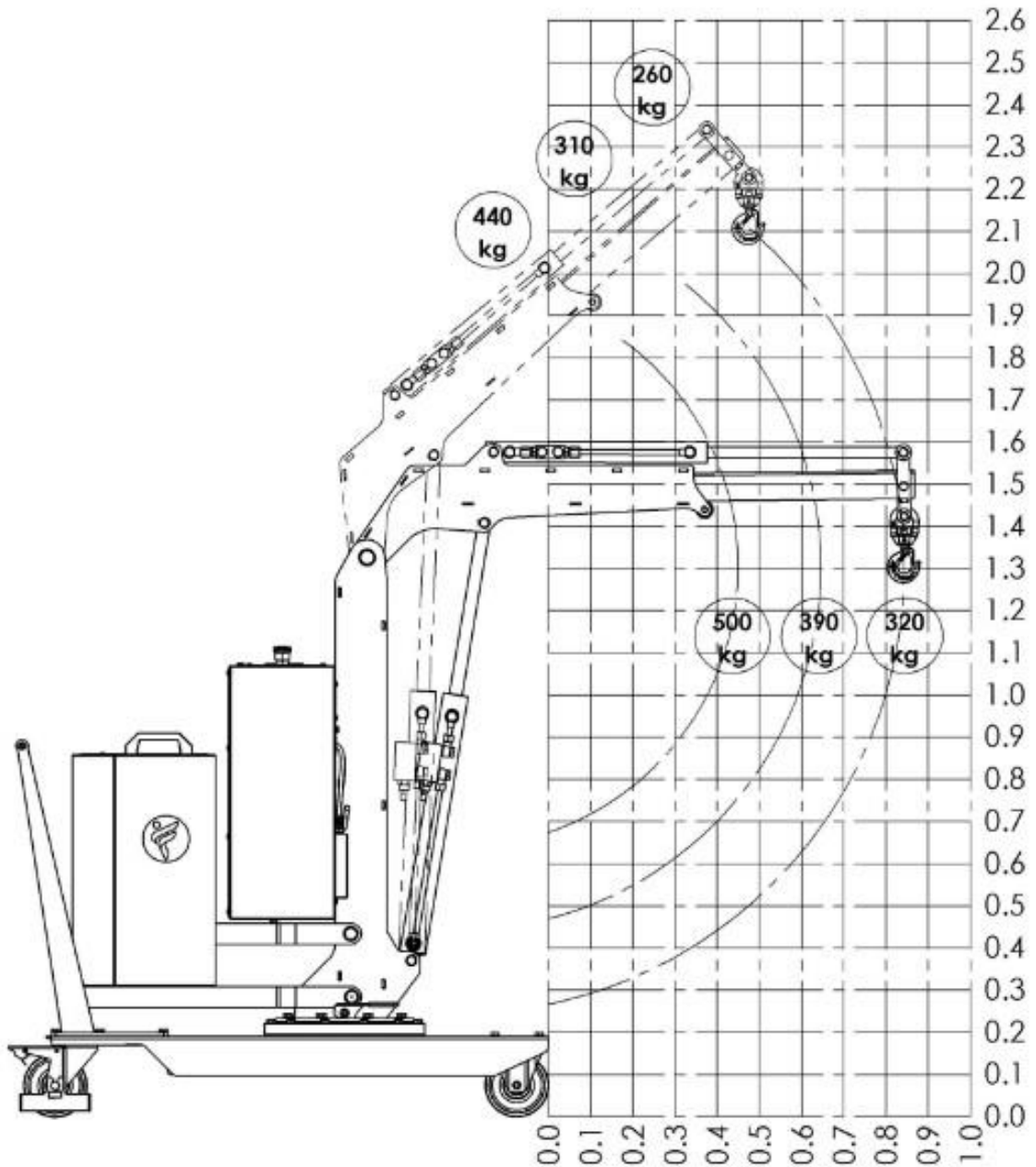

## CRANE 01B5SE\_400

### LOAD CHART WITH OPTIONAL MECHANICAL EXTENSION PZG\_SE

