



CRANE 01B2L

LIFTING CAPACITY 200 KG

COUNTERBALANCED SWIVEL CRANE ELECTRIC LIFT AND LOWER THROUGH
CONTROL LEVER AT ADJUSTABLE SPEED



Model		01B2L
Drive		Manual
Rotation		360° manual - slewing bearing system
Arm lifting		Electric – control lever
Arm lowering		Electric – control lever
Arm extension		Manual – lockable in 4 positions
Width with arm not rotated	mm/inch.	780 / 30
Width with arm rotated at 90°	mm/inch.	1040 / 41
Max capacity with standard arm	Kg / lbs.	200 / 440 * see load chart below
Max capacity with extension PZG1_MBP	Kg / lbs.	115 / 253 * see load chart below
Max capacity with extension PZG2_MBP	Kg / lbs.	91 / 200 * see load chart below
Max capacity with extension PZG3_MBP	Kg / lbs.	67 / 147 * see load chart below
Weight of the crane (counterweight incl.)	Kg / lbs.	440 / 970
Battery type standard		Lead acid
Batteries nos.	pcs	1
Battery voltage / nominal capacity	V / Ah	12 / 80
Lifting motor	W	-
Traction motor	W	-

CRANE 01B2L MAIN DIMENSIONS

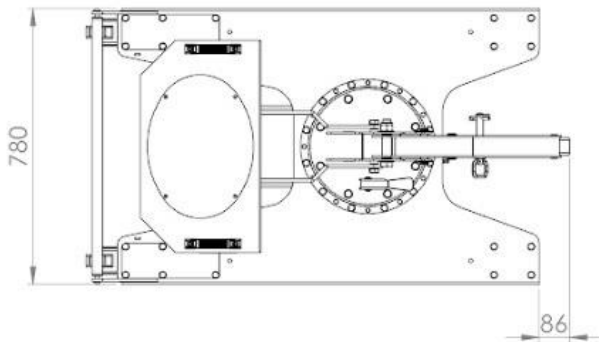
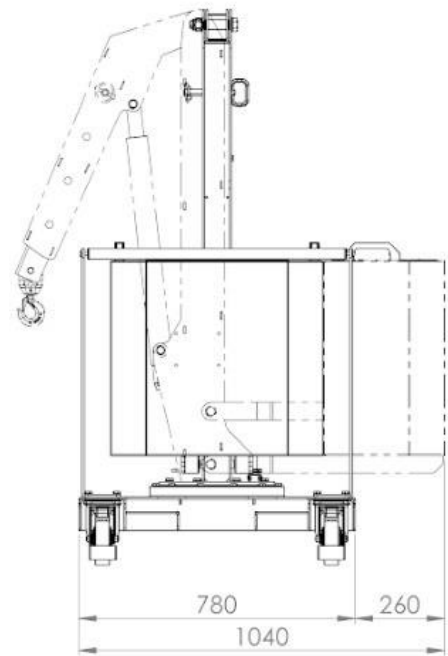
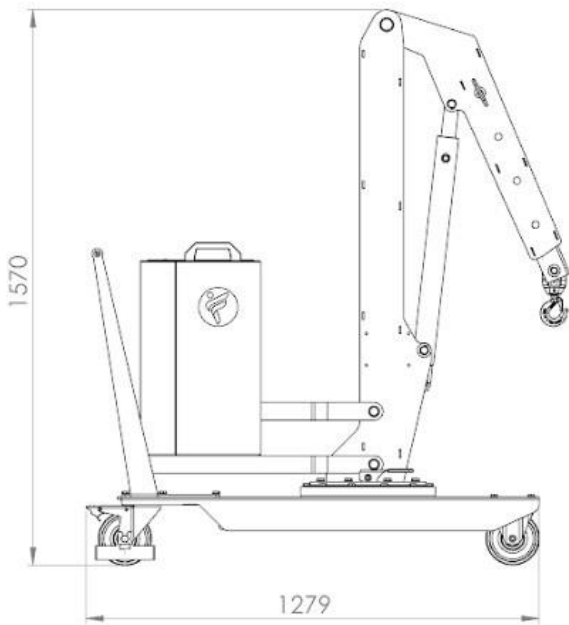

CRANE 01B2L DETAILED DIMENSIONS WITH STANDARD ARM

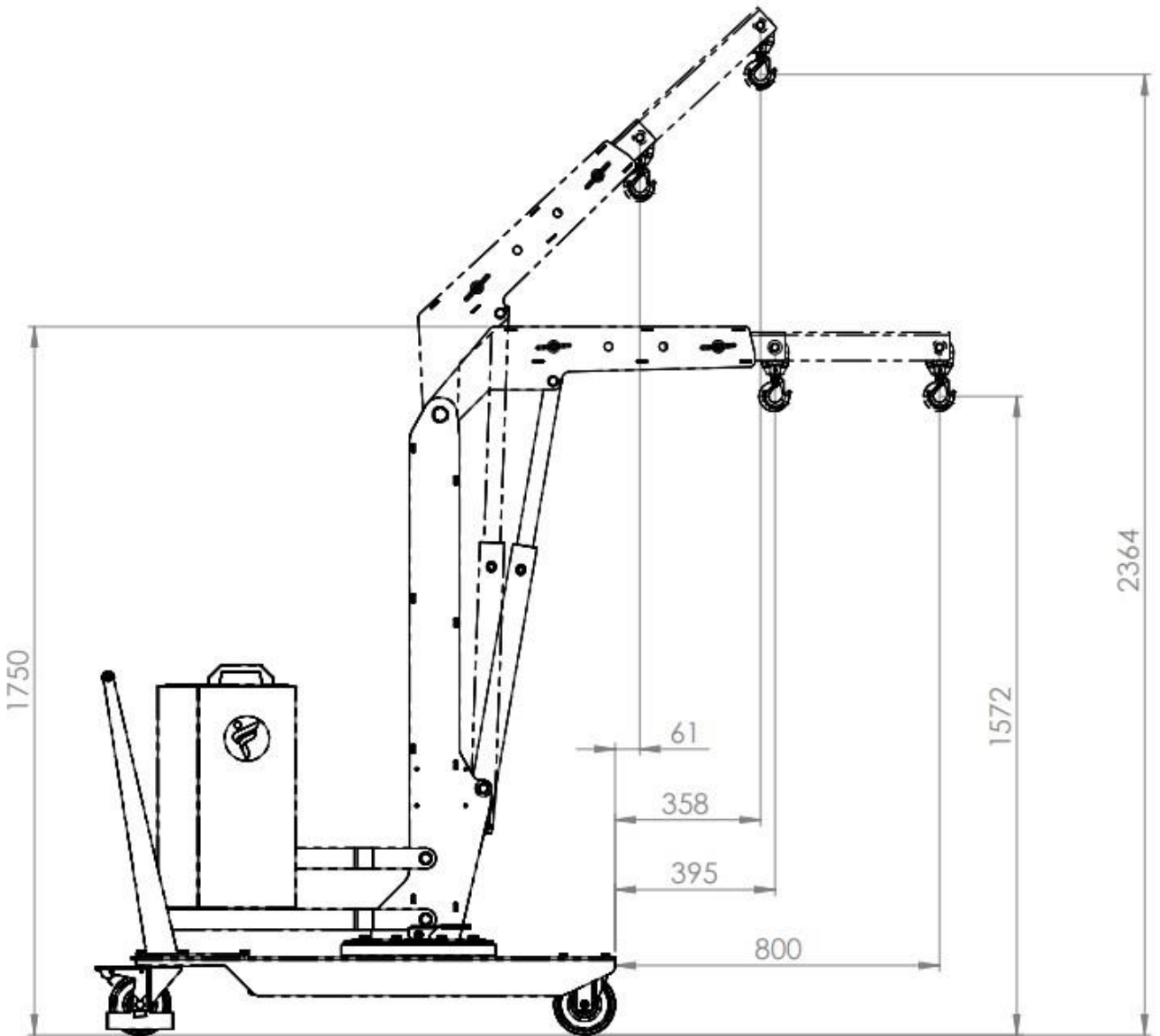

CRANE 01B2L MAIN DIMENSIONS

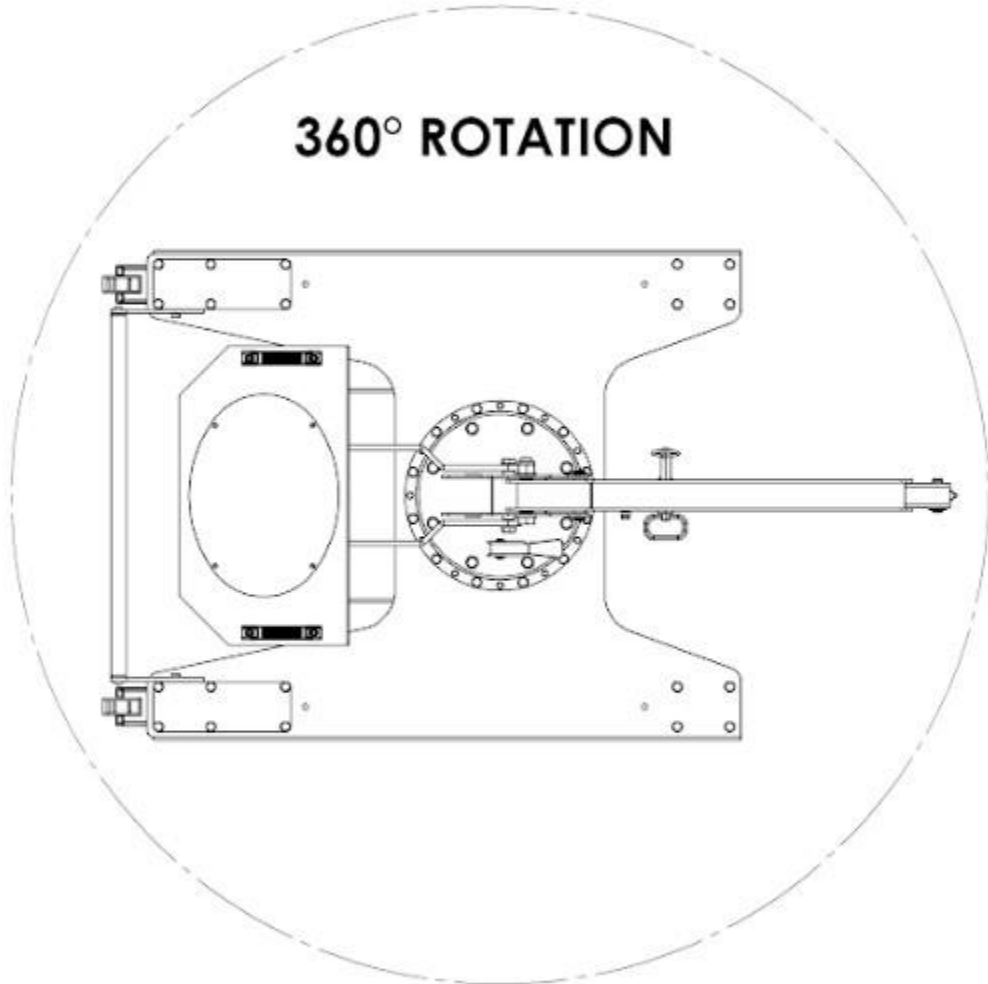

CRANE 01B2L LOAD CHART WITH STANDARD ARM

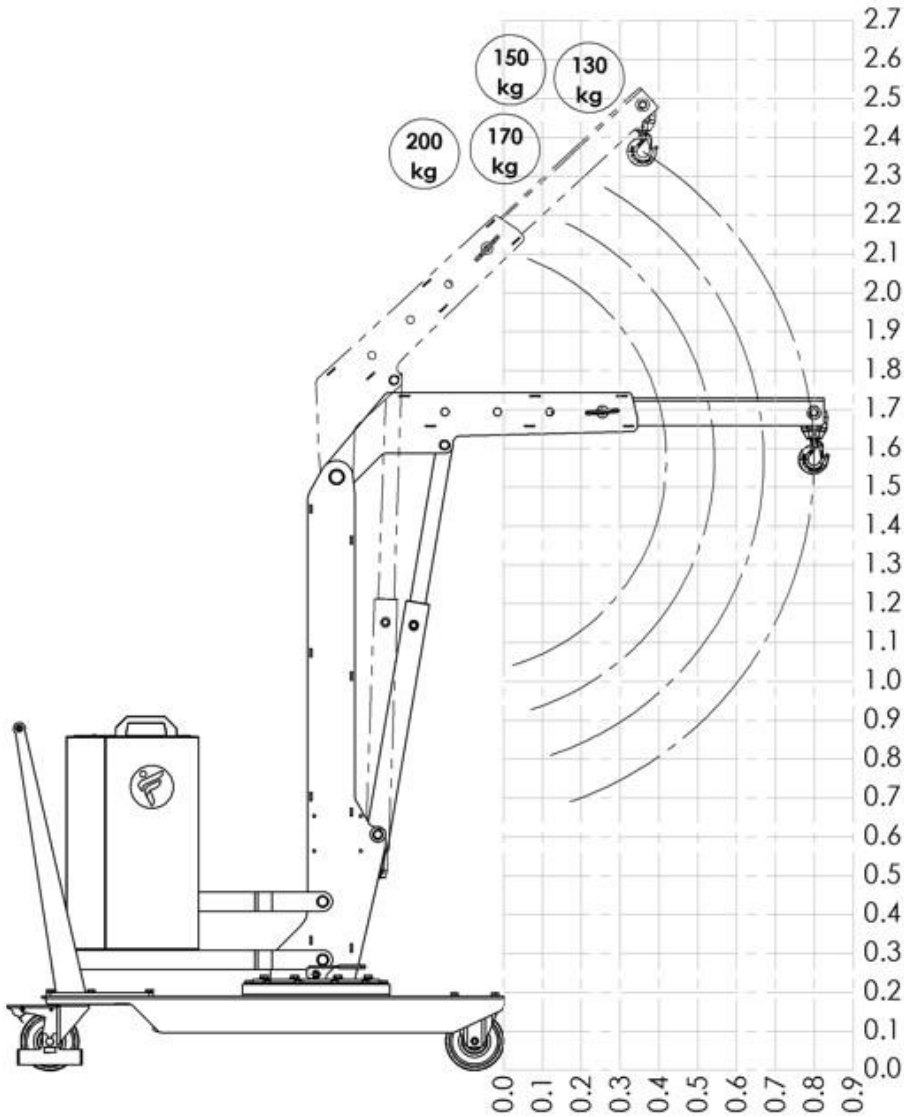

POS.	OVERHANG MM / INCH.	CAPACITY KG / LBS.
1	365 / 14	200 / 440
2	500 / 20	170 / 374
3	635 / 25	150 / 330
4	770 / 30	130 / 286

LiftSafe

LTD.
Specialist Materials Handling Solutions
CRANE 01B2L

LOAD CHART WITH OPTIONAL EXTENSION PZG1-MBP

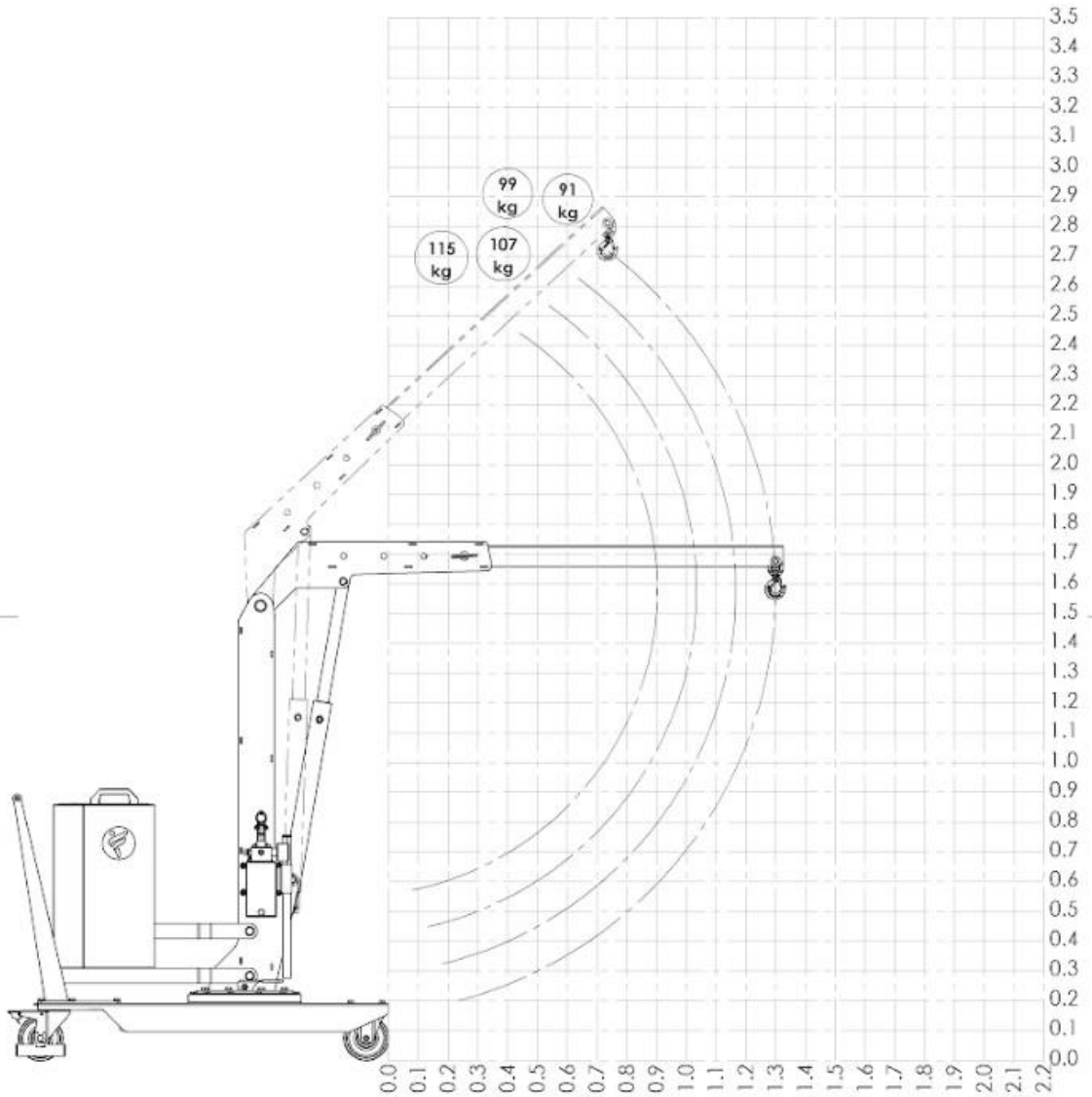

POS.	OVERHANG MM / INCH.	CAPACITY KG / LBS.
1	865 / 34	115 / 253
2	1000 / 39	107 / 235
3	1135 / 45	99 / 218
4	1270 / 50	91 / 200

CRANE 01B2L

LOAD CHART WITH OPTIONAL EXTENSION PZG2-MBP

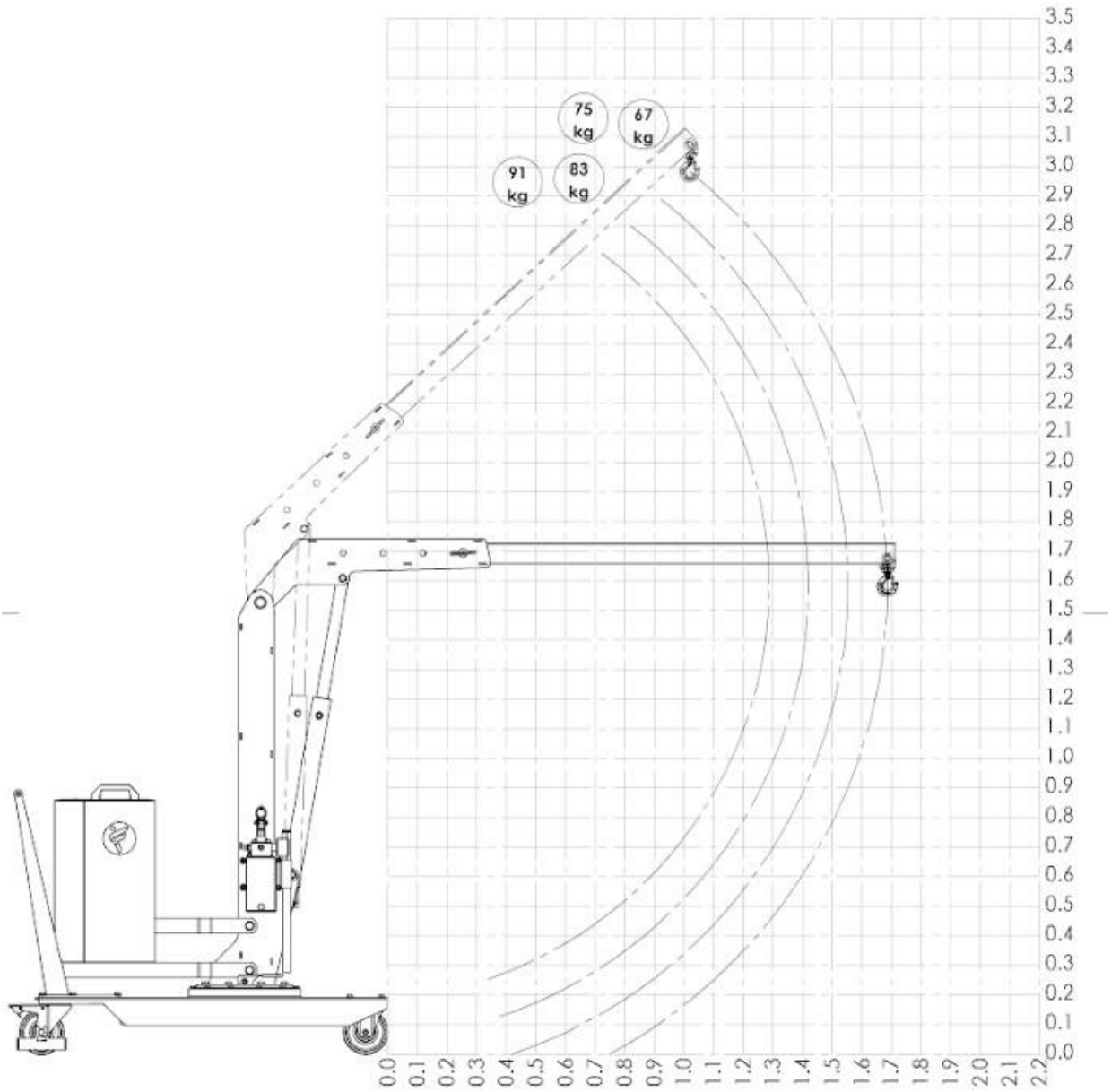

POS.	OVERHANG MM / INCH.	CAPACITY KG / LBS.
1	1250 / 49	91 / 200
2	1385 / 54	83 / 182
3	1520 / 60	75 / 165
4	1655 / 65	67 / 147

CRANE 01B2L

LOAD CHART WITH OPTIONAL EXTENSION PZG3-MBP

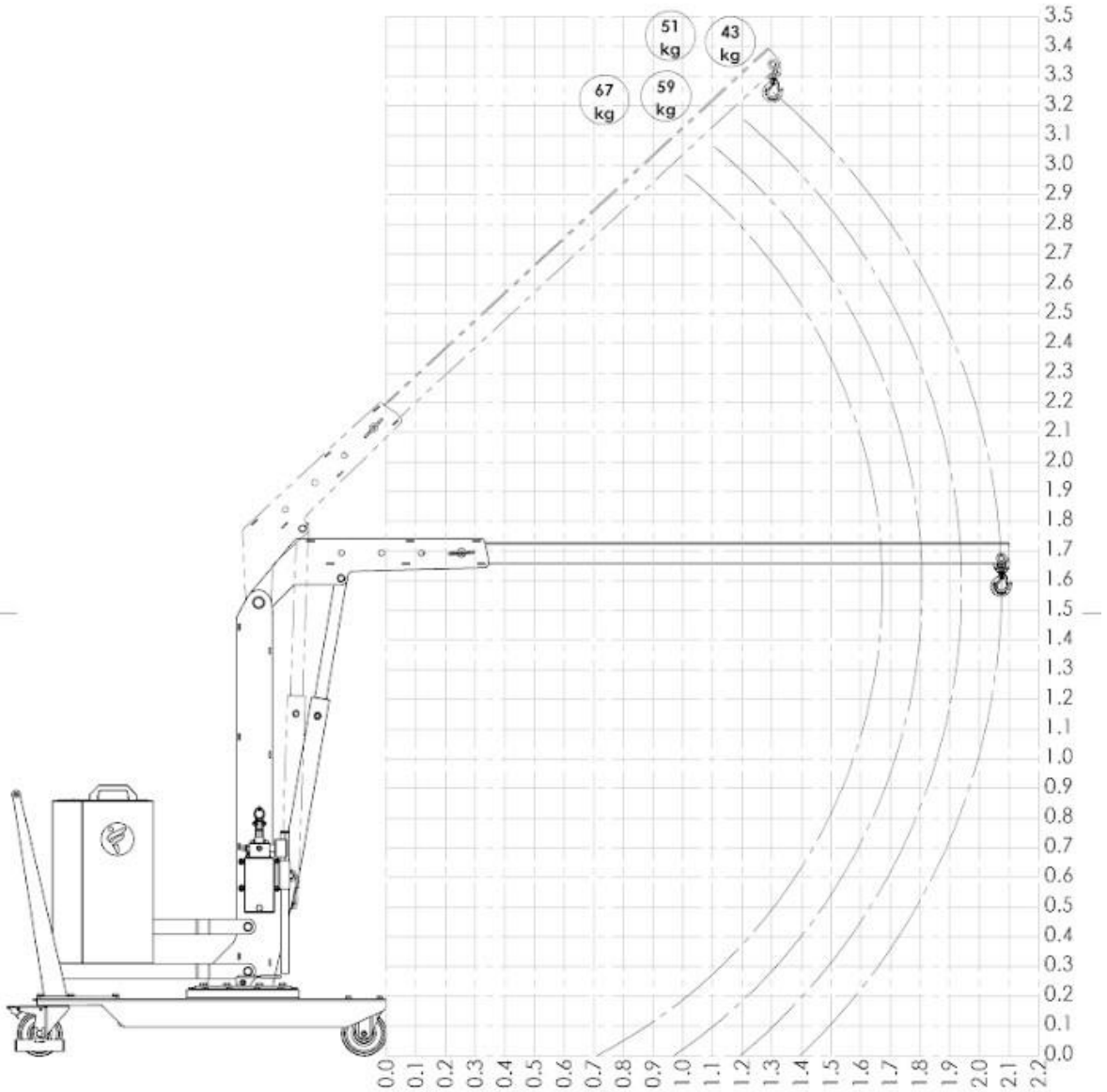

POS.	OVERHANG MM / INCH.	CAPACITY KG / LBS.
1	1645 / 65	67 / 147
2	1780 / 70	59 / 130
3	1915 / 75	51 / 112
4	2050 / 81	43 / 95