

CRANE OMNIA 2TR

LIFTING CAPACITY 2000 KG

MOTORISED COUNTERBALANCED CRANE WITH RIGID ARM AND TRIPLE TELESCOPIC BOOM
ELECTRIC LIFT/LOWER/EXTEND/RETRACT THROUGH RADIO CONTROL WITH PROPORTIONAL JOYSTICK



Model		OMNIA 2TR
Drive		Electric
Rotation		Rigid arm
Arm lifting		Electric – radio control
Arm lowering		Electric – radio control
Arm extension		Electric – radio control
Width	mm/inch.	1116 / 44
Max capacity with standard triple boom	Kg / lbs.	2000 / 4409 * see load chart below
Weight of the crane (counterweight incl.)	Kg / lbs.	1900 / 4188
Battery type standard		Maintenance free AGM
Batteries nos.	pcs	2
Battery voltage / nominal capacity	V / Ah	12 / 120
Lifting motor	W	3000
Traction motor	W	1200

CRANE OMNIA 2TR MAIN DIMENSIONS

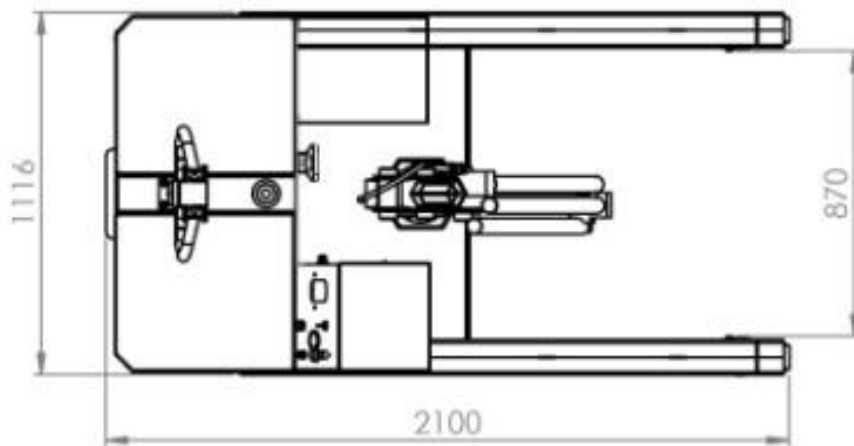
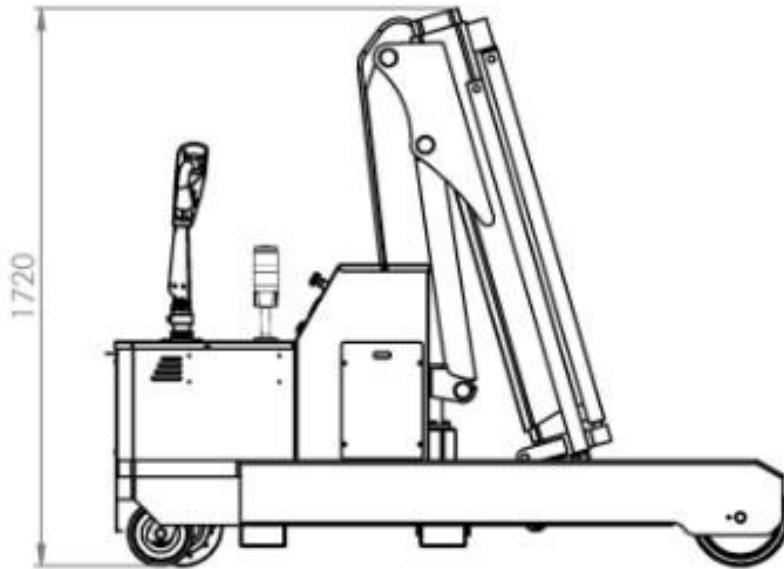

CRANE OMNIA 2TR DETAILED DIMENSIONS WITH STANDARD TELESCOPIC ELECTRIC TRIPLE BOOM

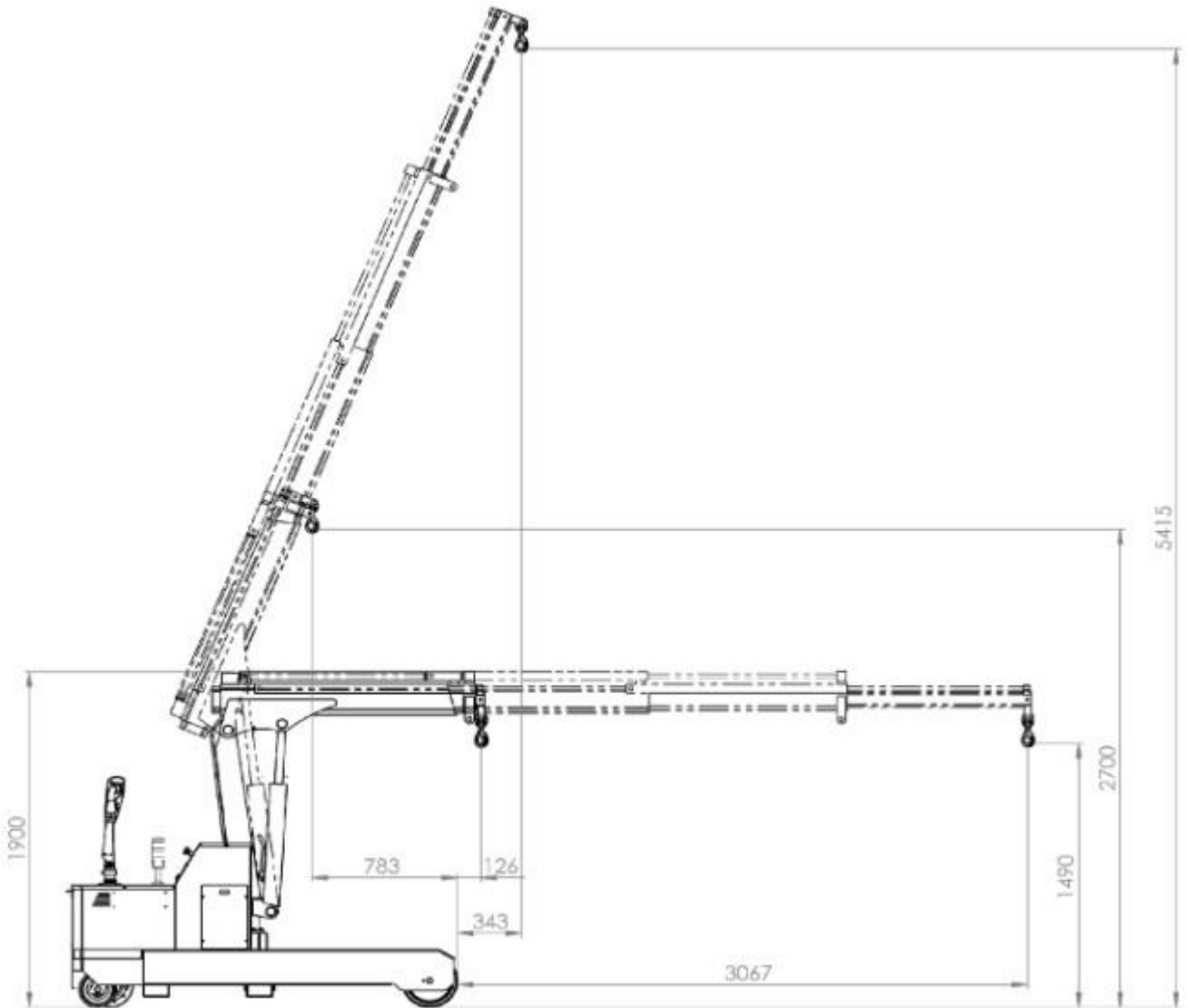

CRANE OMNIA 2TR LOAD CHART

