

## CRANE FLEX G500SBR

LIFTING CAPACITY 500 KG

MOTORISED COUNTERBALANCED SWIVEL CRANE

ELECTRIC LIFT/LOWER/EXTEND/RETRACT THROUGH PUSH BUTTON REMOTE CONTROL  
AT ADJUSTABLE SPEED



| Model                                     |           | FLEX G500SBR                         |
|-------------------------------------------|-----------|--------------------------------------|
| Drive                                     |           | Electric                             |
| Rotation                                  |           | 270° manual - slewing bearing system |
| Arm lifting                               |           | Electric – remote control            |
| Arm lowering                              |           | Electric – remote control            |
| Arm extension                             |           | Electric – remote control            |
| Width with arm not rotated                | mm/inch.  | 990 / 39                             |
| Width with arm rotated at 90°             | mm/inch.  | 1018 / 40                            |
| Max capacity with standard arm            | Kg / lbs. | 500 / 1102 * see load chart below    |
| Max capacity with extension PZG_SE        | Kg / lbs. | 100 / 220 * see load chart below     |
| Weight of the crane (counterweight incl.) | Kg / lbs. | 910 / 2006                           |
| Battery type standard                     |           | Maintenance free AGM                 |
| Batteries nos.                            | pcs       | 2                                    |
| Battery voltage / nominal capacity        | V / Ah    | 12 / 120                             |
| Lifting motor                             | W         | 800                                  |
| Traction motor                            | W         | 1200                                 |

## CRANE FLEX G500SBR MAIN DIMENSIONS

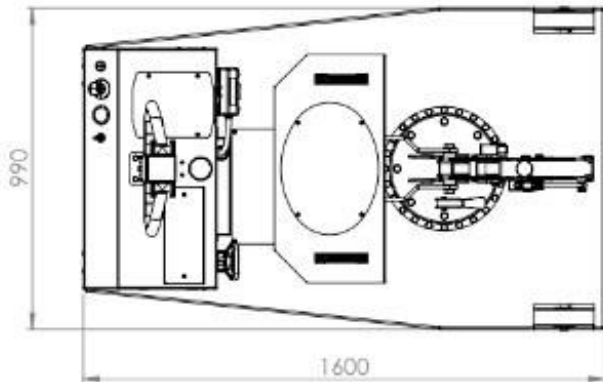
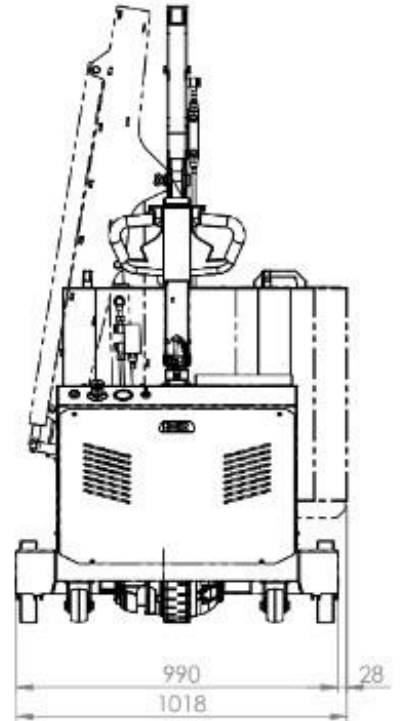
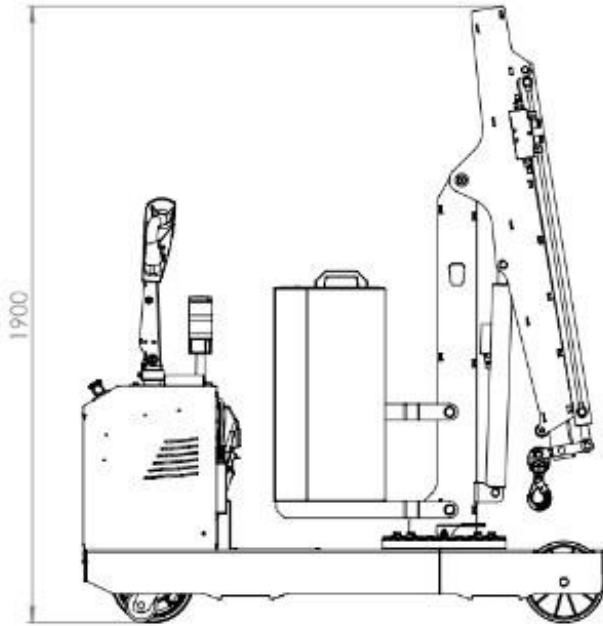

## CRANE FLEX G500SBR DETAILED DIMENSIONS WITH STANDARD ELECTRIC ARM

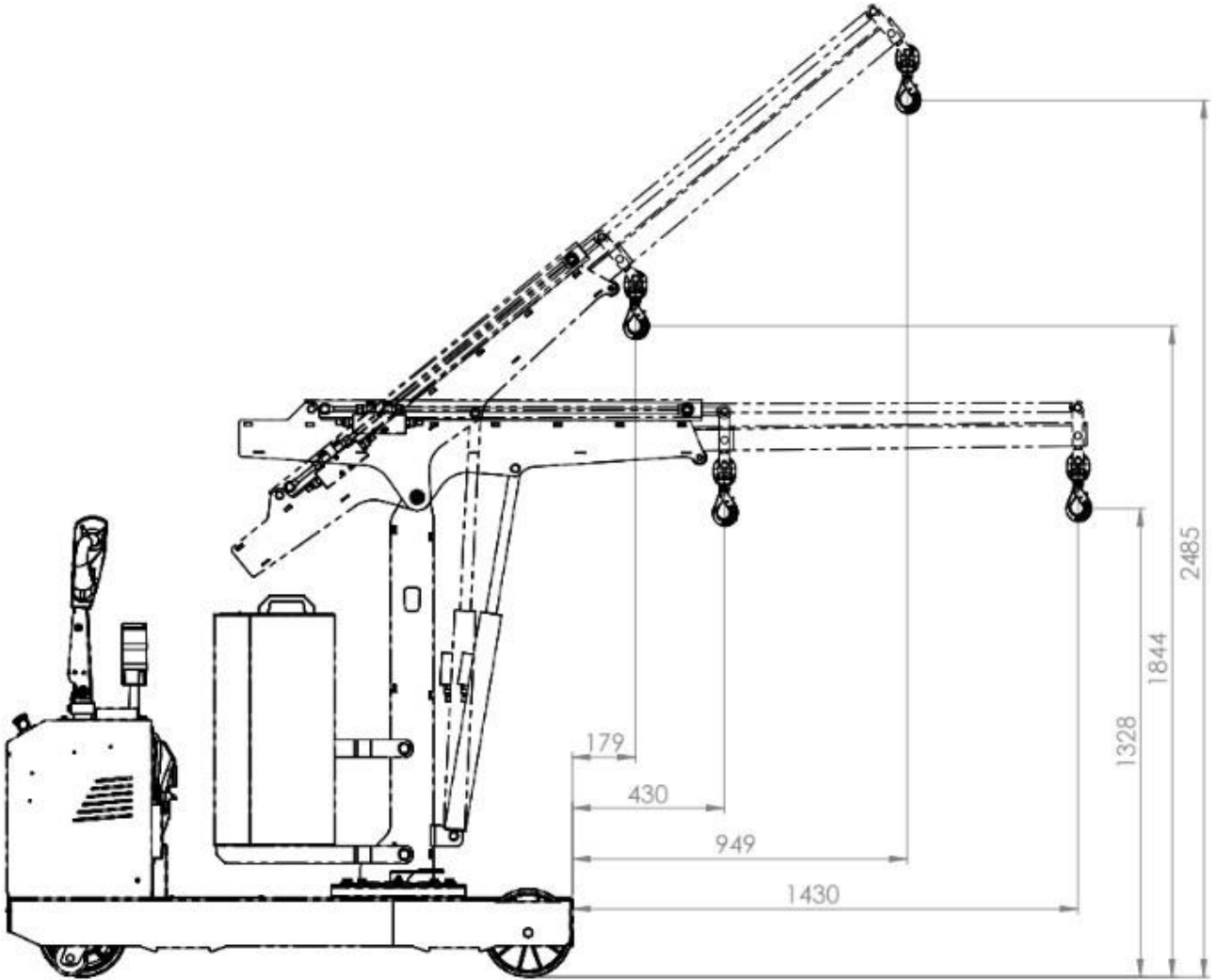

## CRANE FLEX G500SBR MAIN DIMENSIONS

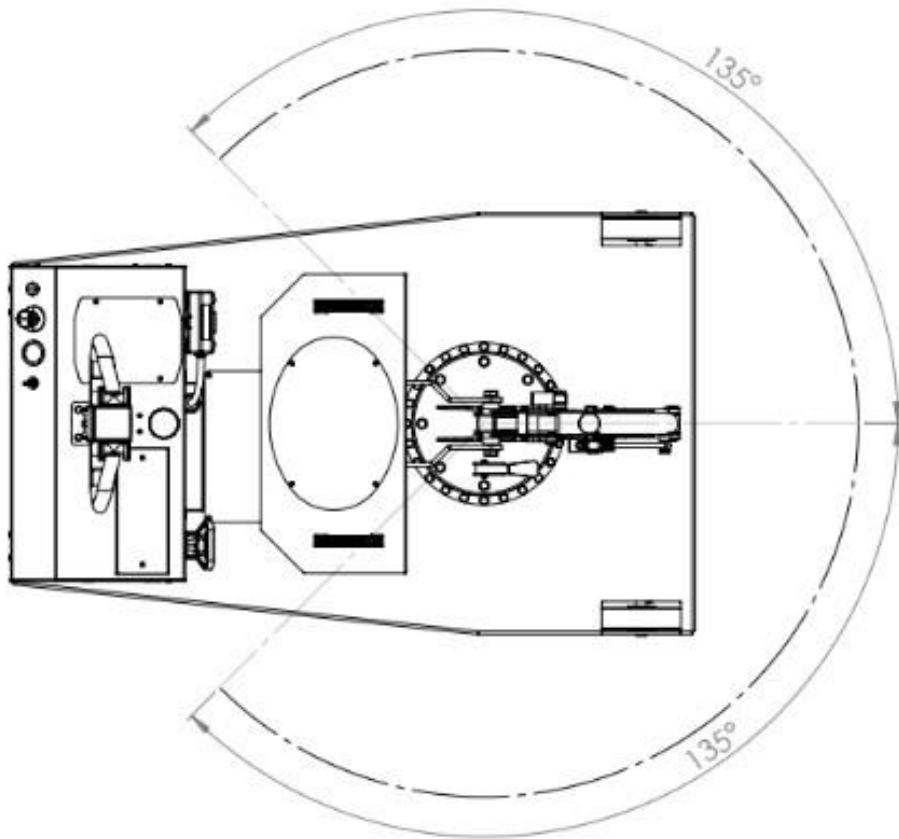

## CRANE FLEX G500SBR LOAD CHART WITH STANDARD ELECTRIC ARM

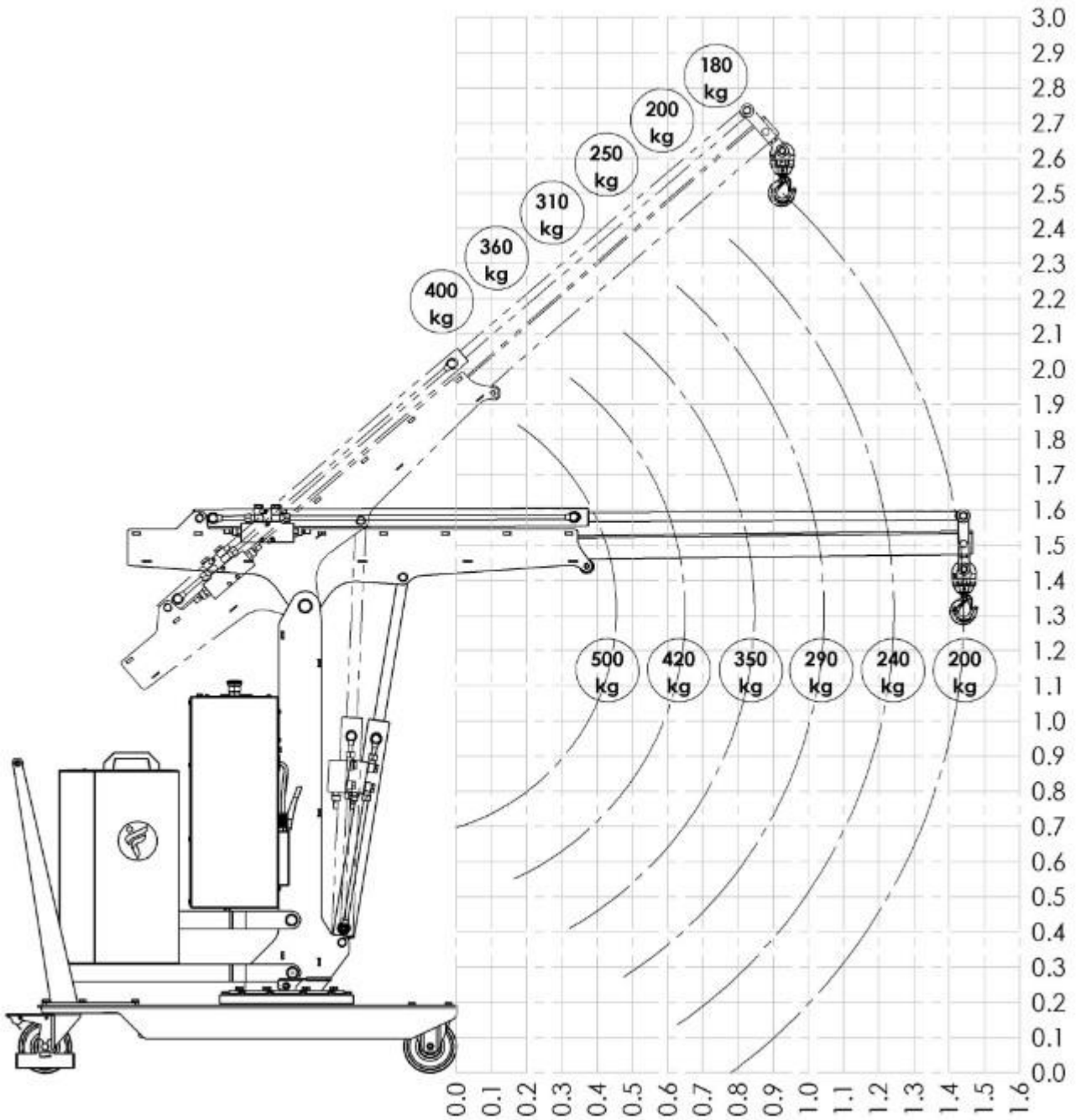

## CRANE FLEX G500SBR LOAD CHART WITH OPTIONAL MECHANICAL EXTENSION PZG\_SE

