

CRANE FLEX G500SBL

LIFTING CAPACITY 500 KG

MOTORISED COUNTERBALANCED SWIVEL CRANE

ELECTRIC LIFT/LOWER/EXTEND/RETRACT THROUGH CONTROL LEVERS AT ADJUSTABLE SPEED



Model		FLEX G500SBL
Drive		Electric
Rotation		270° manual - slewing bearing system
Arm lifting		Electric – control lever
Arm lowering		Electric – control lever
Arm extension		Electric – control lever
Width with arm not rotated	mm/inch.	990 / 39
Width with arm rotated at 90°	mm/inch.	1018 / 40
Max capacity with standard arm	Kg / lbs.	500 / 1102 * see load chart below
Max capacity with extension PZG_SE	Kg / lbs.	100 / 220 * see load chart below
Weight of the crane (counterweight incl.)	Kg / lbs.	910 / 2006
Battery type standard		Maintenance free AGM
Batteries nos.	pcs	2
Battery voltage / nominal capacity	V / Ah	12 / 120
Lifting motor	W	800
Traction motor	W	1200

CRANE FLEX G500SBL MAIN DIMENSIONS

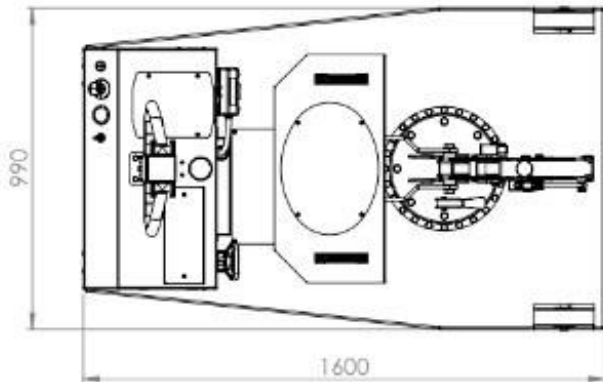
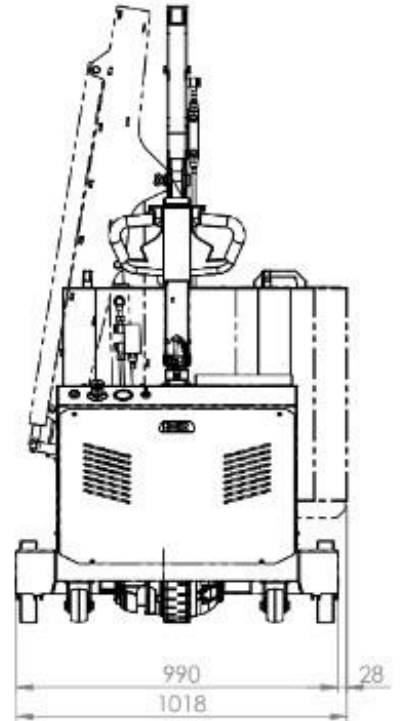
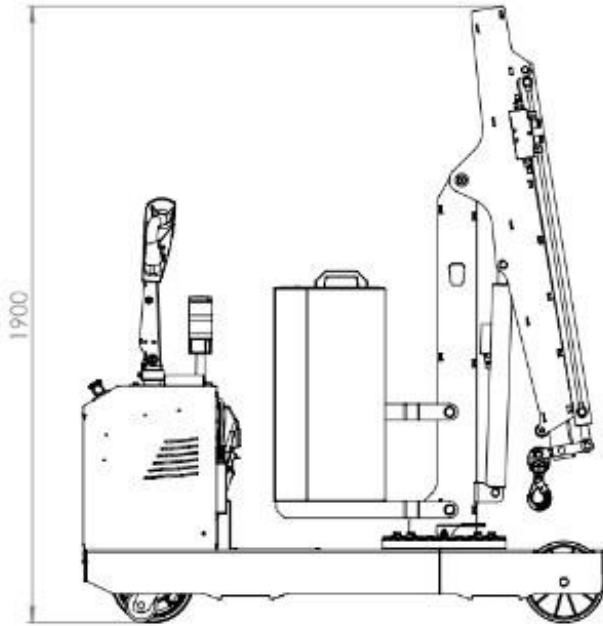

CRANE FLEX G500SBL DETAILED DIMENSIONS WITH STANDARD ELECTRIC ARM

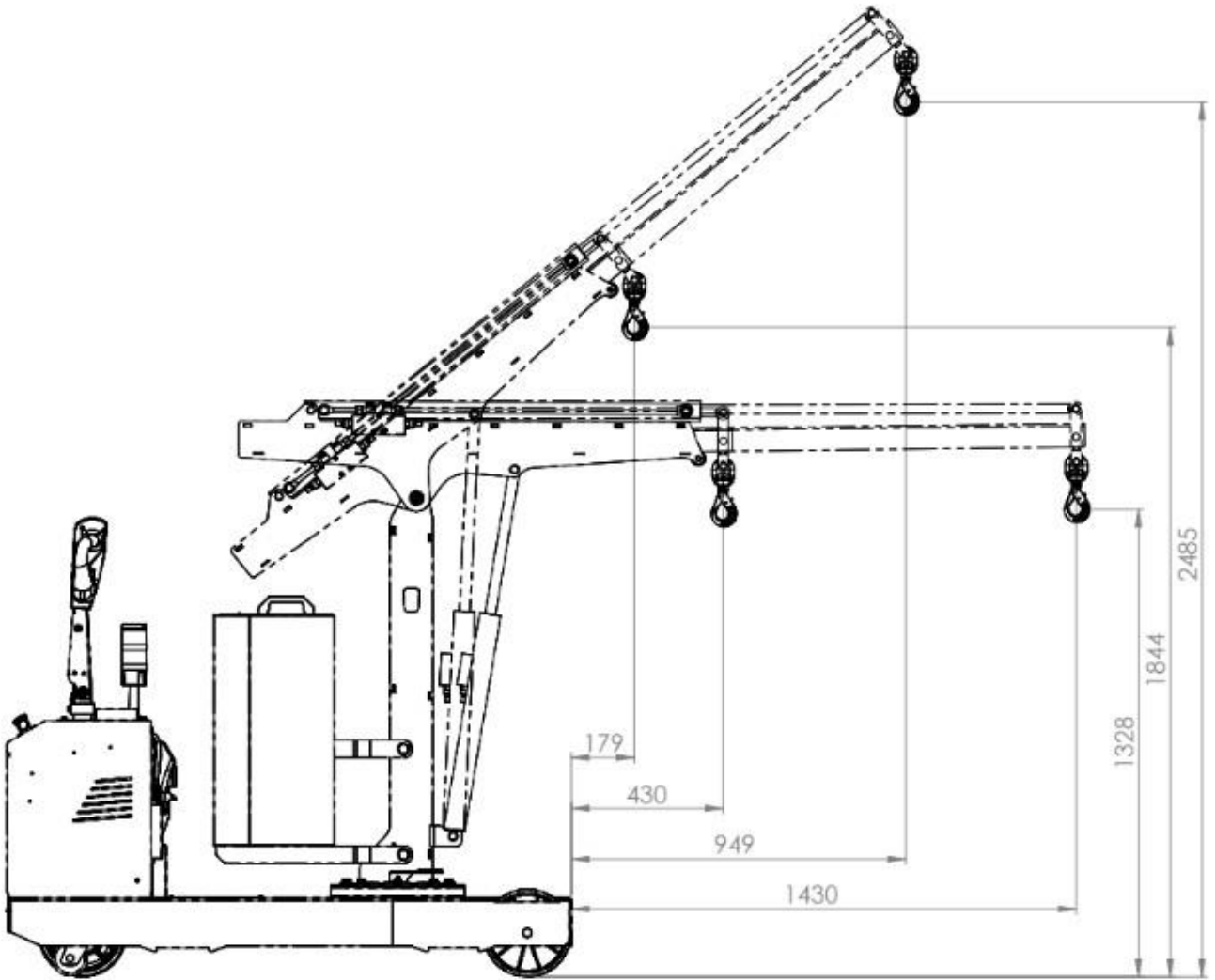

CRANE FLEX G500SBL MAIN DIMENSIONS

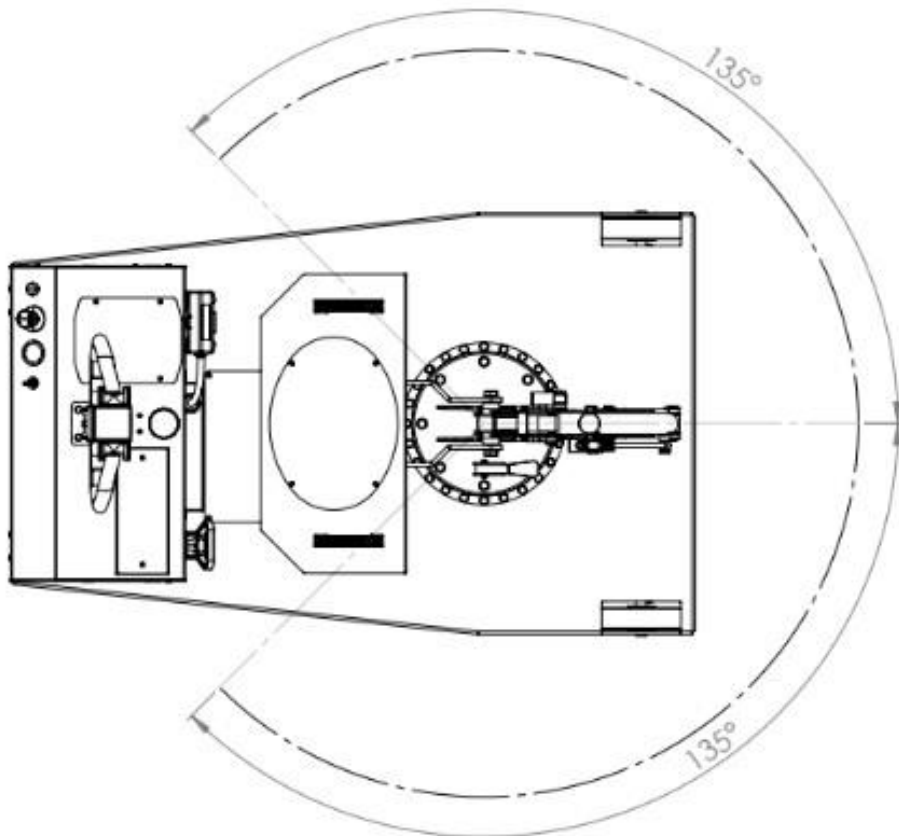

CRANE FLEX G500SBL LOAD CHART WITH STANDARD ELECTRIC ARM

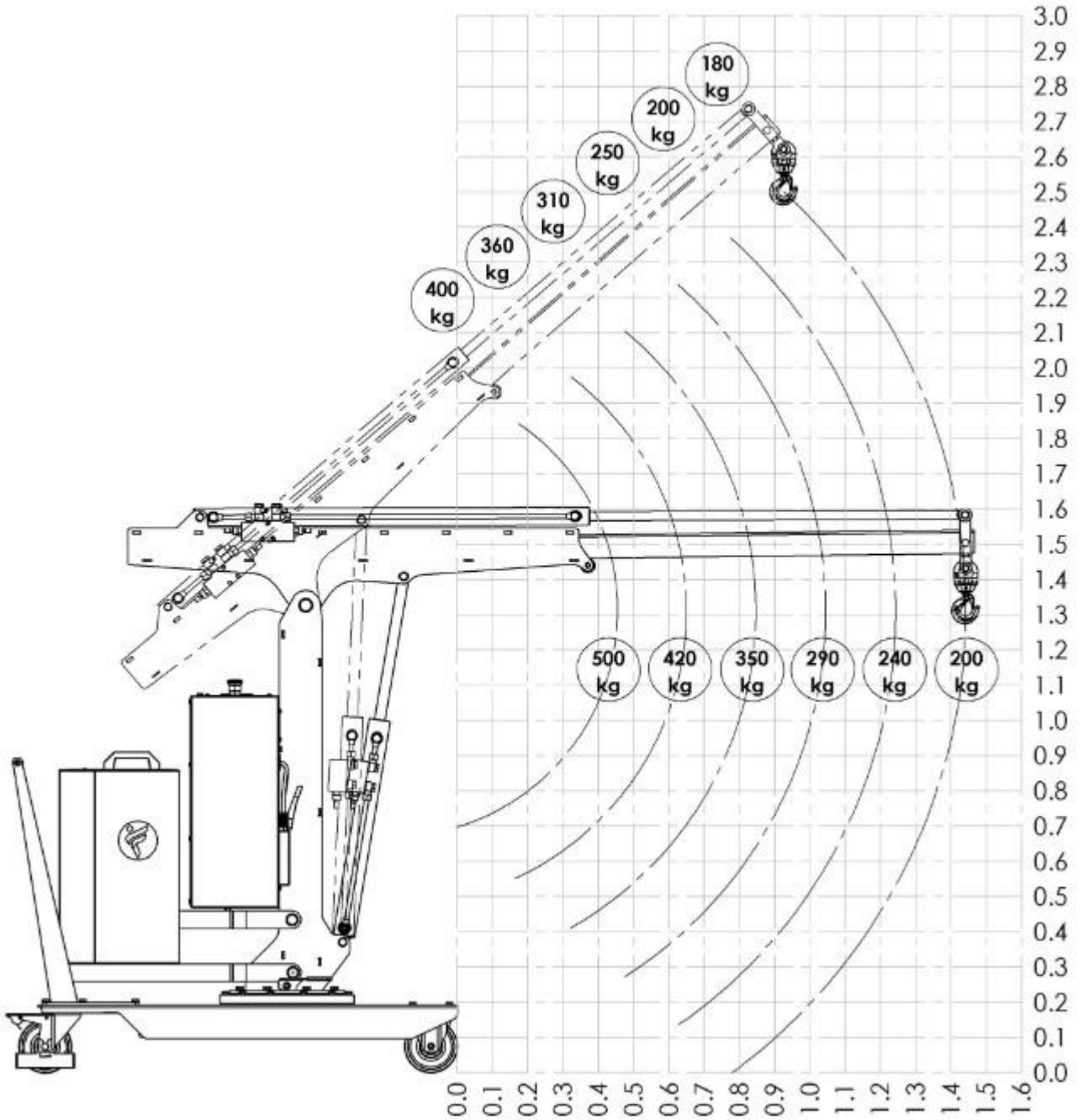

CRANE FLEX G500SBL

LOAD CHART WITH OPTIONAL MECHANICAL EXTENSION PZG_SE

