

CRANE FLEX F1000DBR

LIFTING CAPACITY 1000 KG

MOTORISED COUNTERBALANCED CRANE WITH RIGID ARM AND DOUBLE TELESCOPIC BOOM
ELECTRIC LIFT/LOWER/EXTEND/RETRACT THROUGH PUSH BUTTON REMOTE CONTROL
AT ADJUSTABLE SPEED



Model		FLEX F1000DBR
Drive		Electric
Rotation		Rigid arm
Arm lifting		Electric – remote control
Arm lowering		Electric – remote control
Arm extension		Electric – remote control
Width	mm/inch.	780 / 30
Max capacity with standard double boom	Kg / lbs.	1000 / 2204 * see load chart below
Weight of the crane (counterweight incl.)	Kg / lbs.	1600 / 3527
Battery type standard		Maintenance free AGM
Batteries nos.	pcs	2
Battery voltage / nominal capacity	V / Ah	12 / 120
Lifting motor	W	800
Traction motor	W	1200

CRANE FLEX F1000DBR MAIN DIMENSIONS

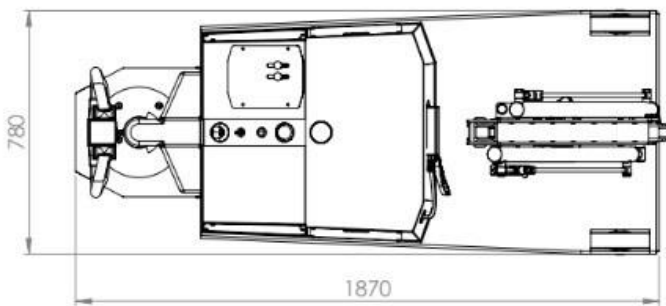
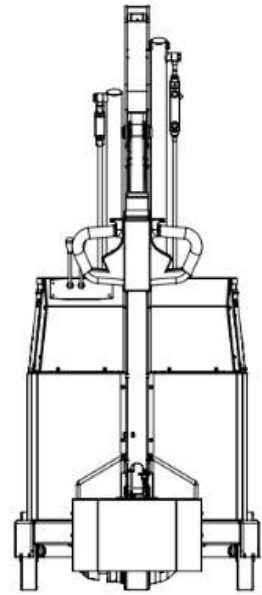
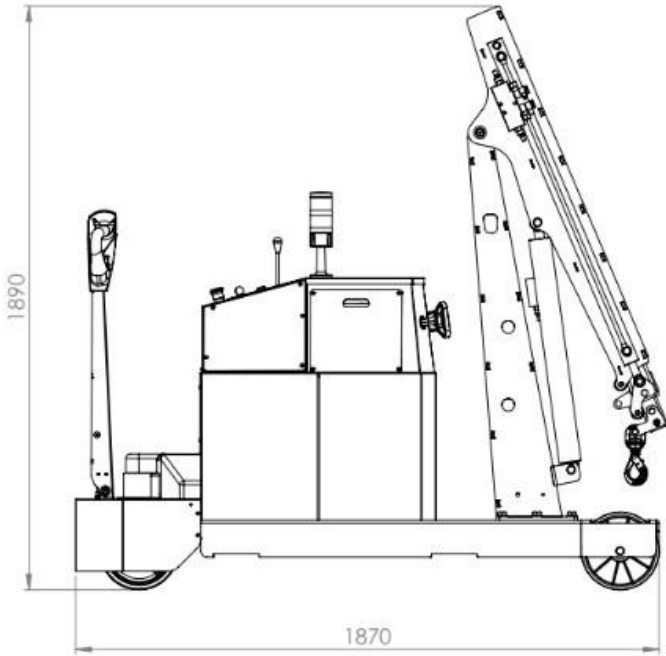

CRANE FLEX F1000DBR DETAILED DIMENSIONS WITH STANDARD TELESCOPIC ELECTRIC DOUBLE BOOM

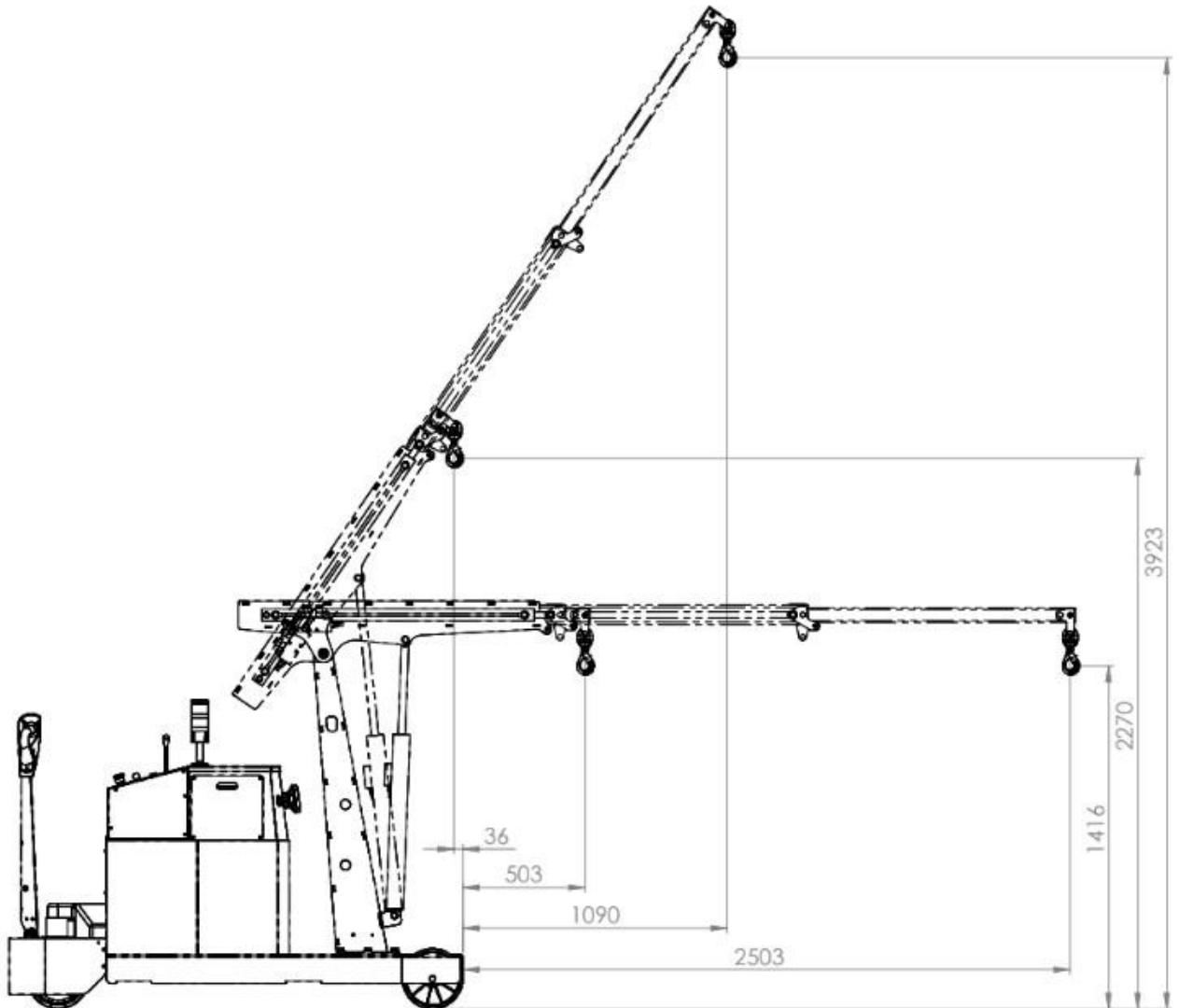

CRANE FLEX F1000DBR LOAD CHART

