

CRANE ATLAS 1TE3L

LIFTING CAPACITY 1000 KG

MOTORISED COUNTERBALANCED CRANE WITH RIGID ARM AND TRIPLE TELESCOPIC BOOM
ELECTRIC LIFT/LOWER/EXTEND/RETRACT THROUGH CONTROL LEVERS AT ADJUSTABLE SPEED



Model		ATLAS 1TE3L
Drive		Electric
Rotation		Rigid arm
Arm lifting		Electric – control lever
Arm lowering		Electric – control lever
Arm extension		Electric – control lever
Width	mm/inch.	780 / 30
Max capacity with standard triple boom	Kg / lbs.	1000 / 2204 * see load chart below
Weight of the crane (counterweight incl.)	Kg / lbs.	1600 / 3527
Battery type standard		Maintenance free AGM
Batteries nos.	pcs	2
Battery voltage / nominal capacity	V / Ah	12 / 120
Lifting motor	W	2200
Traction motor	W	1200

CRANE ATLAS 1TE3L MAIN DIMENSIONS

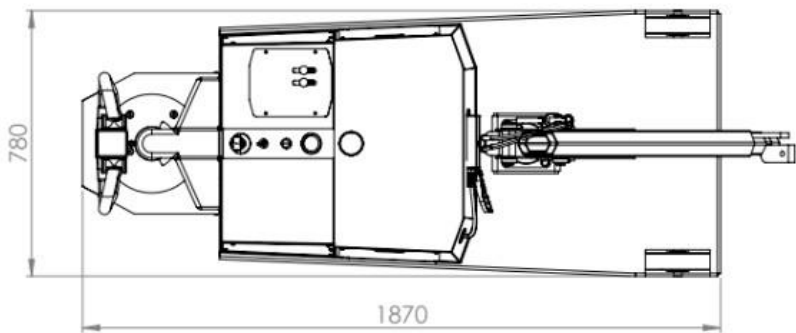
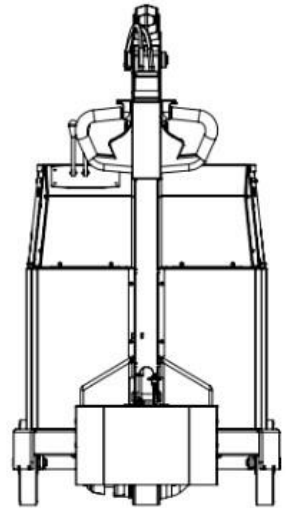
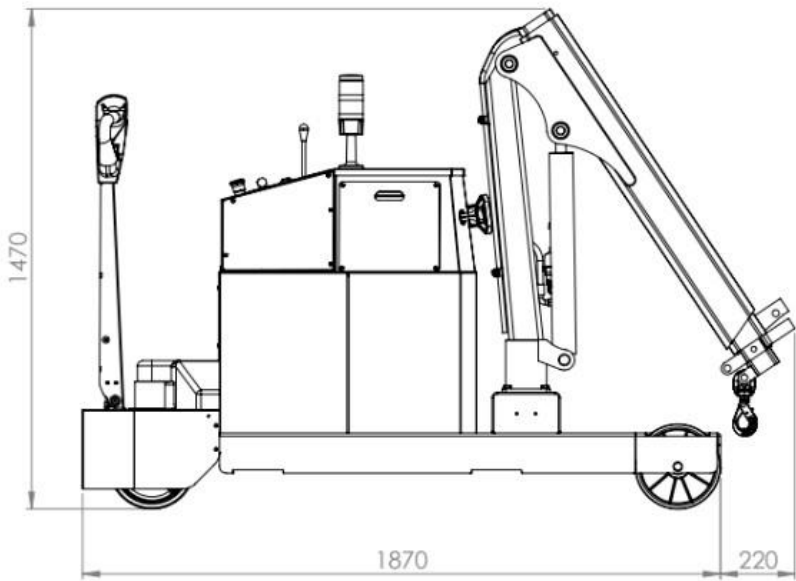

CRANE ATLAS 1TE3L DETAILED DIMENSIONS WITH STANDARD TELESCOPIC ELECTRIC TRIPLE BOOM

