

**ORBIT 200EL (LEVER CONTROLLED)
ORBIT 200ER (REMOTE CONTROLLED)
CAPACITY 200KG - DOUBLE ELECTRIC BOOM**



Models ORBIT 200EL and ORBIT 200ER – a swivel pick & carry crane , full electric powered , with a maximum capacity up to 200 kg. One of the key features of this pick and carry crane is that there are no lateral outriggers, therefore this crane grants max mobility with suspended load.

ORBIT 200EL and ORBIT 200ER are the motorized cranes with the smallest footprint in their category, being 800 mm wide and 1200mm long. It has an excellent steering angle that allows it to move along the narrow spaces or rotate on its axis in limited spaces.

Maximum lifting height 3700 mm.

Free overhang (from the end of the base) both lateral and frontal reach up to 2000 mm .

Ballast does not exceed the crane width of 800mm, even when rotated.

Equipped with AGM batteries that can be recharged in areas with limited ventilation.

Orbit 200EL and 200ER are a full electric crane that can be used in all sectors being silent, environmentally friendly and zero-emission. In line with Health and Safety international standards (emergency buttons, warning devices, relief and check valves). Both models are equipped with a maximum load dynamic throttling device , which prevents the crane from loading beyond maximum range at each point of the slide by inhibiting the ascent and feed controls until the operator re-enter the load within the permitted limits.

They can be equipped with any type of under hook accessory (vacuum lifter, bars, beans, clamps, tilters, permanent magnets and customised solutions) for unlimited applications in a large variety of industries.

Technical data	UM	ORBIT 200EL/200ER
Weight	[kg]	800
Max capacity	[kg]	200
Lifting motor	[W]	800
Traction motor	[W]	1200
Tank capacity	[L]	4

Traction and controller			
2 AGM airtight batteries		1 battery charger	
[V]	[A]	[V]	[A]
2 x 12	2 x 120	24	12

ORBIT 200EL / ORBIT 200ER

CAPACITY 200 KG

LOADING CHART

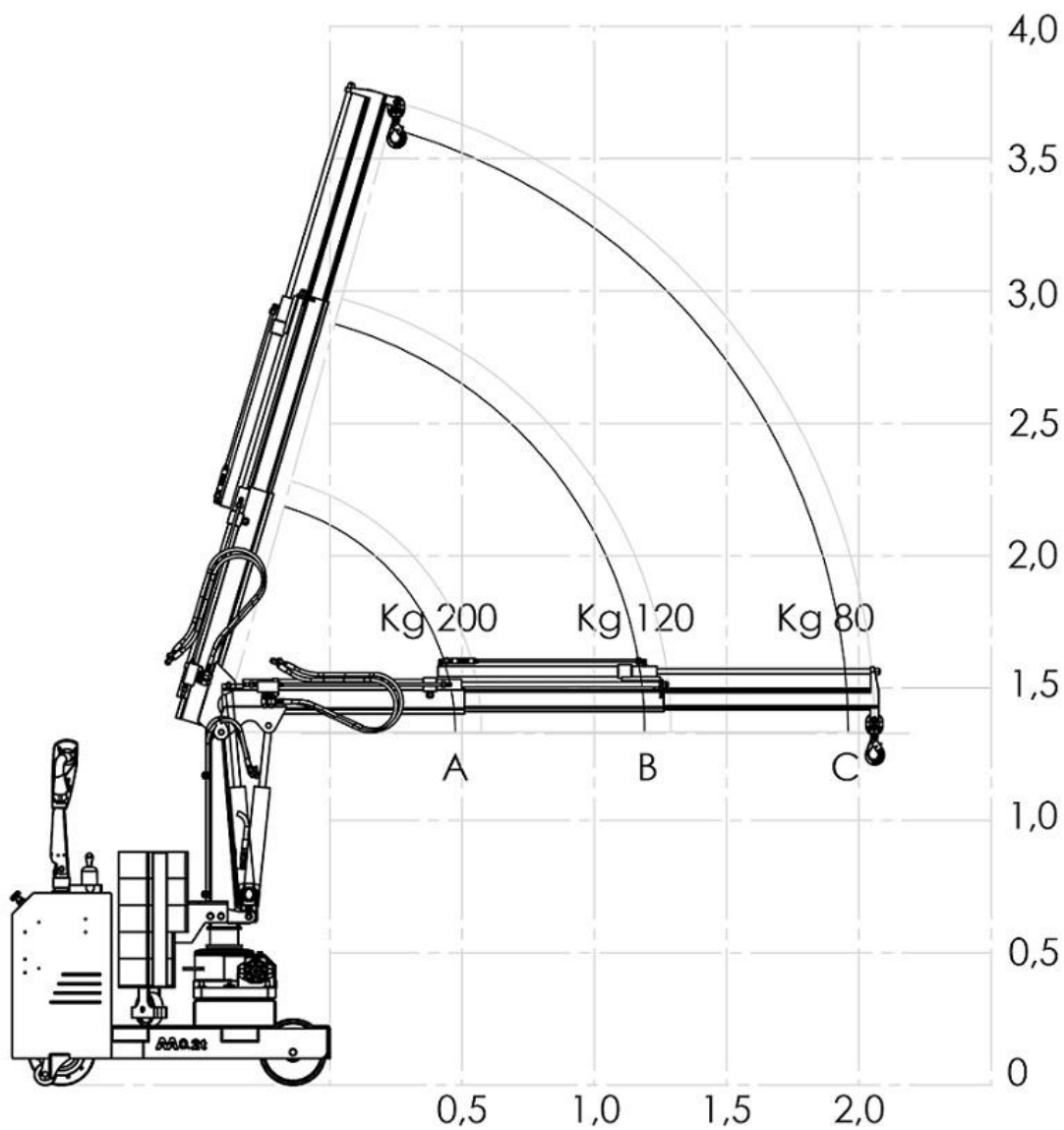

ORBIT 200EL / ORBIT 200ER

CAPACITY 200 KG WITH DOUBLE ELECTRIC BOOM

TILLER ARM

Maximum ergonomics : the operator can firmly grip the tiller handles with both hands

Safe driving : Tiller arm safety switch disables operation in non-allowed positions

Slow/fast speed : 2-speed driving

Slow mode of 1.5 km/hr ideal for tight spaces and to safely move the load

Standard speed of 3.0 km/hr to drive the crane along long distances

Audible motion warning device : Horn with anti-noise polyester axial capacitor

Anti-crush belly button: anti-crush button with automatic reversing switch to ensure the safety of the operator in every maneuvering operation

2 butterfly controls: for forward travel and backward travel controls



CONTROLS, WARNING LIGHTS AND STANDARD FEATURES

2 position **key switch** ; **emergency button** ; **Green indicator light** showing maximum load position and the upward/downward motion and extension & retraction motion are active; **Red control light** showing maximum load capacity (when the red light is activated is not possible to lift the load and extend the jib); Indicator showing the **battery charge level**; **Schuko socket** for 220V charge ; Visual warning **LED beacon**; **24V intermittent buzzer** when the crane is moving to increase operator safety; **Storage compartment**.

ORBIT 200EL is equipped with proportional control levers with adjustable speed

- 1) controls jib upward/downward motion
- 2) controls jib extension & retraction
- 3) controls column rotation

ORBIT 200ER 200EL is equipped with remote control with proportional and adjustable speed . The remote control handle is equipped with a button , that allows you to activate the proportional control mode.

- 1) Lever that controls the jib upward/downward motion
- 2) Lever that controls the jib extension & retraction
- 3) Lever that controls the column rotation



BUILT-IN CHARGER

Pulse model with single phase 220V high frequency input voltage and 24V output voltage. Microprocessor indicator with relay for lifting block.

3 LEDs that indicate the operating status. **Remote RBC indicator** for displaying the charging phase of the battery charger.



DYNAMIC LOAD LIMITER

System for preventing overloading in each position of the extension that activates a mechanism that blocks the upward and extension motion (red light) ensuring the functionality of the crane in absolute safety and that signals (green light) when the crane returns to allowed position, re-enabling the controls.



POWER DRIVE

AC traction motor with recovery braking. Permanent magnet **drive wheel** in direct current 24V 700W; high frequency **MOSFET controller**.



ORBIT 200EL / ORBIT 200ER

TECHNICAL DRAWINGS, DIMENSIONS AND CAPACITIES
A high-performance and universal crane

