

COUNTERBALANCED SWIVEL CRANE WITH ELECTRIC TRACTION

G500SB CAPACITY 500 KG – SWIVEL CRANE WITH SINGLE ELECTRIC BOOM

G500SB is a power driven counterbalanced swivel crane that make it possible to lift and carry loads up to 500 kg. The rotation is manual controlled and is facilitated by 2 handles positioned in the upper part of the integrated ballast system. Rotating jib arm in 8 locking positions. Equipped with 2 fixed wheels and 2 pivoting stabilizing wheels. Self-braking drive wheel for easy maneuverability in confined spaces. Equipped with airtight AGM batteries. Electric lifting and lowering, extension and retraction at adjustable and proportional speed. Compliant with current legislation for the protection and safety of operators.



Outreach and capacity with standard electric single boom	
Length	from 430 mm to 1430 mm
Capacity	from 500 kg to 200 kg
Outreach and capacity with mechanical extension (delivered as standard accessory) 1930 mm reach and fix capacity of 100 kg	

Traction and controller			
2 x AGM Batteries		1 Battery charger	
[V]	[A]	[V]	[A]
2 x 12	2 x 120	24	12

Technical data	UM	G500SB
Weight	[kg]	910
Max capacity	[kg]	500
Lifting motor	[W]	800
Traction motor	[W]	1200
Tank capacity	[L]	2



DYNAMIC LOAD LIMITER
System for preventing overloading in each position that activates a mechanism that make it not possible to extend the arm.

BUILT-IN CHARGER
Pulse model with single phase 220V high frequency input voltage and 24V output voltage. Microprocessor indicator with relay for lifting block. **3 LEDs** that indicate the operating status. **Remote RBC indicator** for displaying the charging phase of the battery charger.

TILLER ARM

Maximum ergonomics : the operator can firmly grip the tiller handles with both hands

Safe driving : Tiller arm safety switch disables operation in non-allowed positions

Slow/fast speed : 2-speed driving

Slow mode of 1.5 km/hr ideal for tight spaces and to safely move the load

Standard speed of 3.0 km/hr to drive the crane along long distances

Audible motion warning device : Horn with anti-noise polyester axial capacitor

Anti-crush belly button: anti-crush button with automatic reversing switch to ensure the safety of the operator in every maneuvering operation

2 butterfly controls: for forward travel and backward travel controls

CONTROLS, WARNING LIGHTS AND STANDARD FEATURES

2 position key switch ; emergency button ;); Indicator showing the battery charge level; Schuko socket for 220V charge; Visual warning LED beacon; 24V intermittent buzzer when the crane is moving to increase operator safety; Battery recharge cycle indicator. Storage compartment.

EQUIPPED WITH A 4-FUNCTION DISTRIBUTOR FOR:

- **arm lifting**
- **arm lowering**
- **boom extension**
- **boom retraction**

When the joystick lever is moved in the lifting, extension and lowering positions, the micro switches automatically activate the motor of the hydraulic unit which allows the movements; the lowering takes place safely with the engine off.



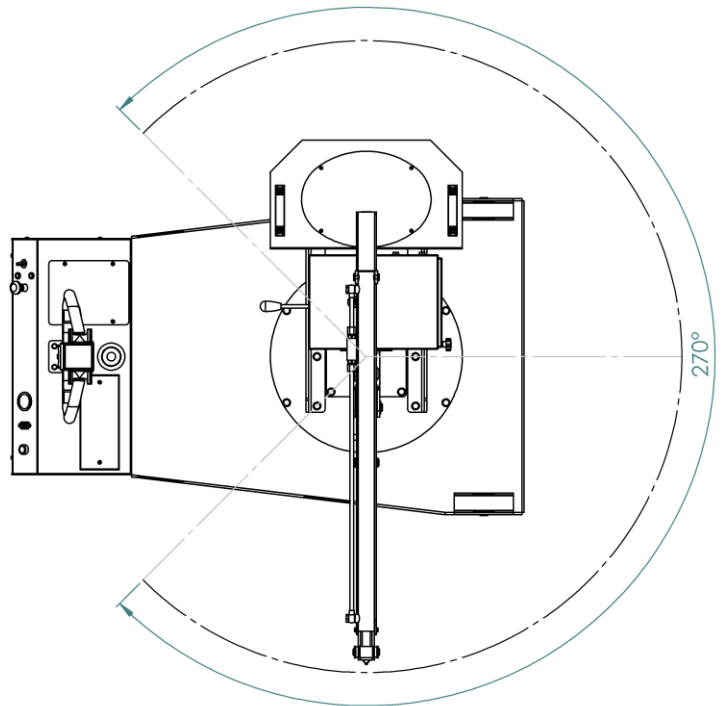
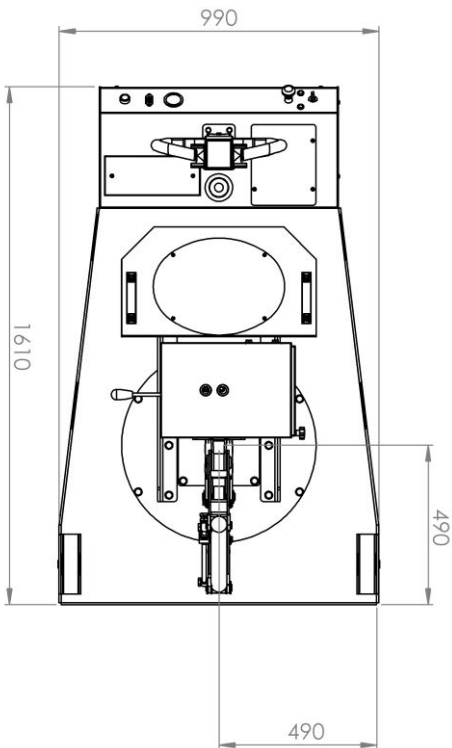
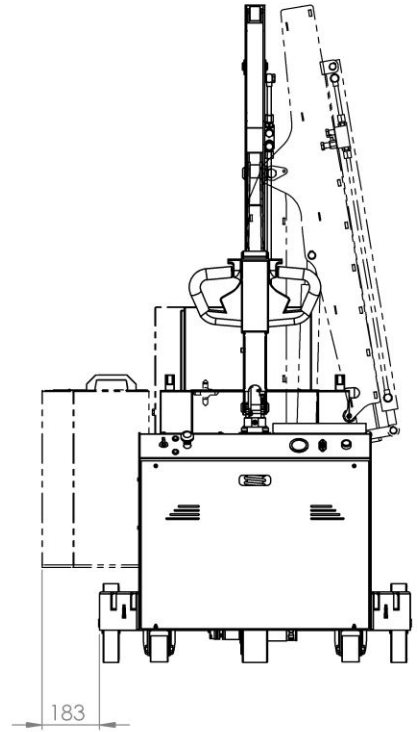
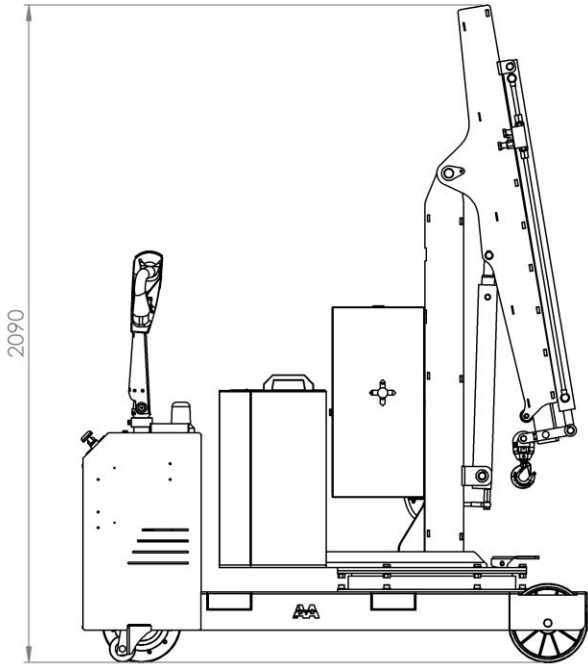

G500SB
SIDE AND FRONT OVERHANG

WITH ELECTRIC SINGLE BOOM

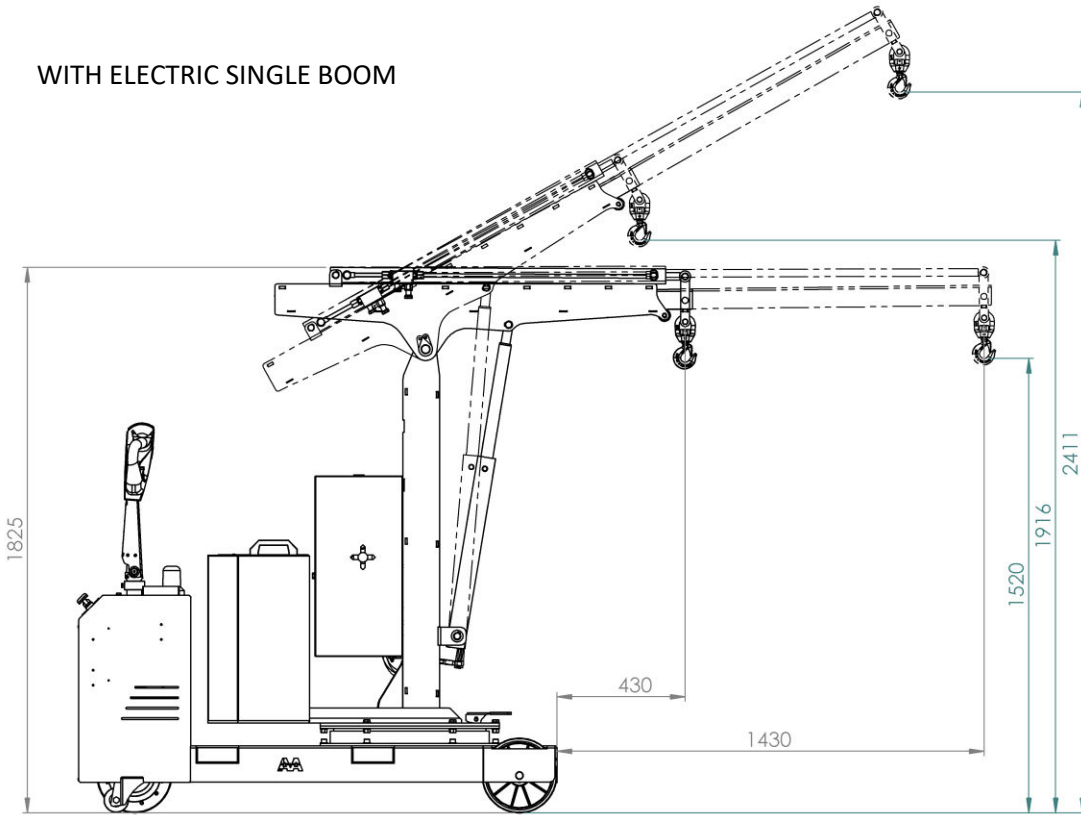

WITH MECHANICAL EXTENSION

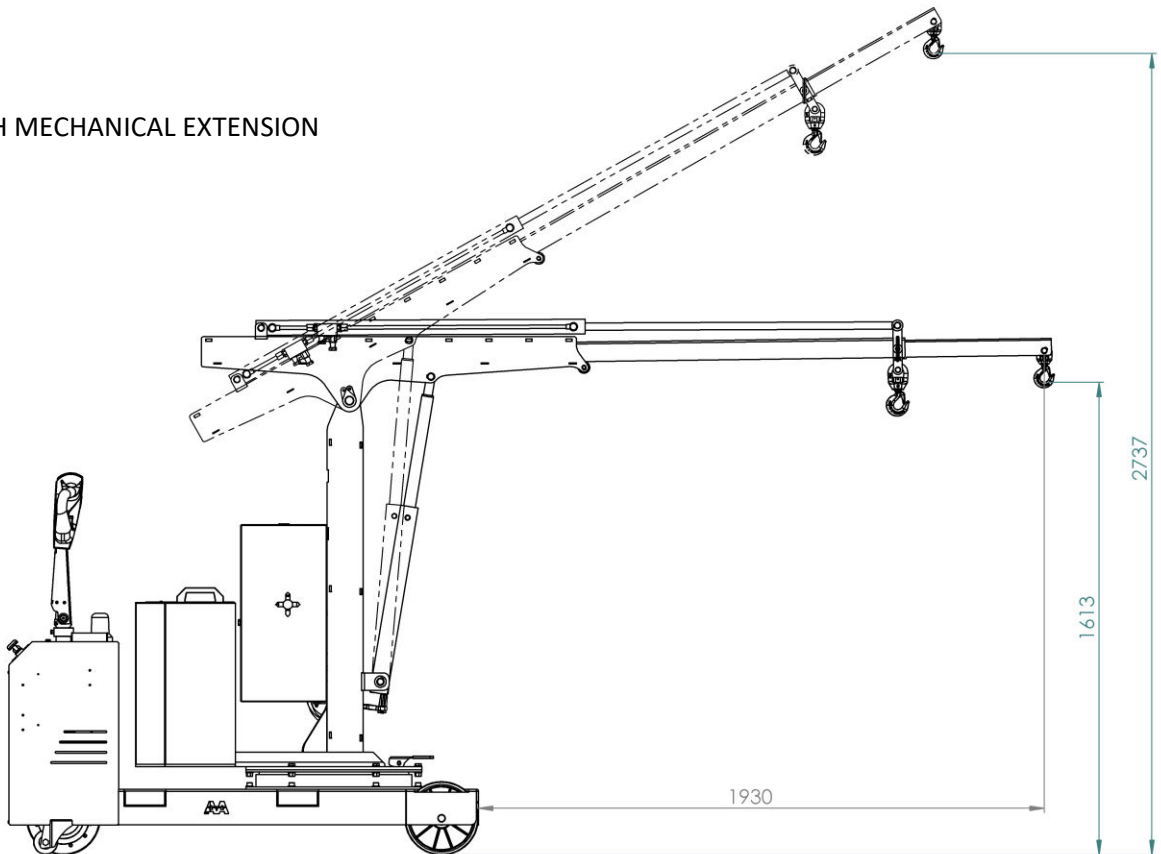

**G500SB
LOAD DIAGRAM**

