

Mod. GZ1000BSE is a counterbalanced crane ideal for placements of loads up to 1000 kg over any barrier/obstruction (on 3D machines, machining centres, lathes, assembly lines, etc).

Jib reaches a distance of 2000 mm with 250 kg of max capacity. It comes with two-fixed wheel and two pivoting wheels with brake.

Easy to handle and move, even at max load. It comes with two safety valves to prevent falling of loads in the event of hose failure and machine overloading.

## GZ1000BSE

4-function  
electric  
distributor



Max cap:  
**1000 KG**



Equipped with a 4-function electric distributor for :

- Lifting
- Lowering
- Jib extension
- Jib retraction

Movements are activated by a lever built-in the electric case.

Extremely precise placements with infinite adjustment speed.

Lowering occurs in off mode.

**GZ1000BSE**

Heavy loads  
placements  
at far  
distance



100% made  
in Italy

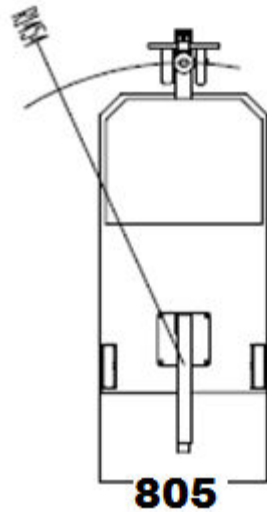
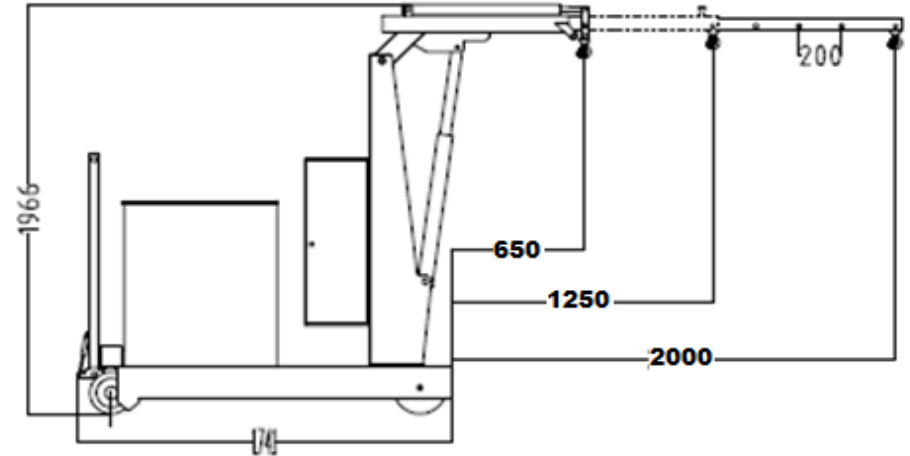
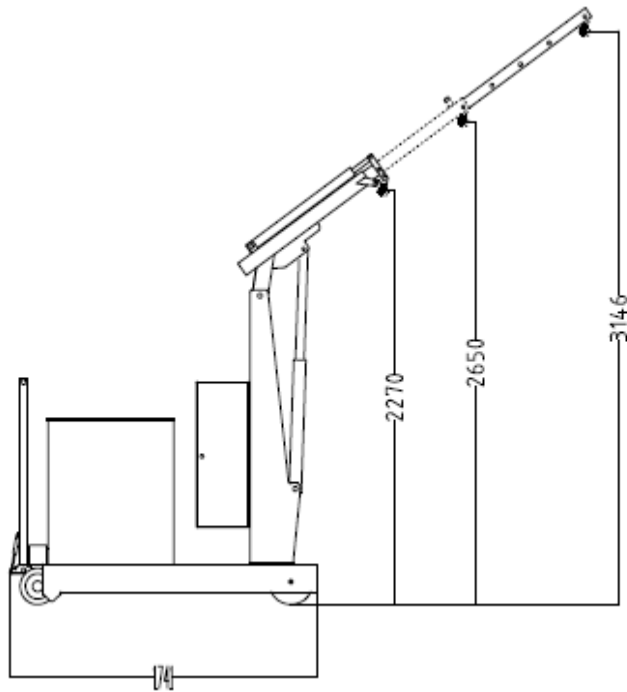

WEIGHT	MAX PRESSURE	CYLINDER		MAX CAPACITY	TANK CAPACITY
1250 KG	95 BAR	STROKE 550 mm	DIAMETER 70 mm	1000 KG	3L

Outreach and max capacity with standard jib	
Length	From 650 mm to 1250 mm
Capacity	from 1000 kg to 500 kg
Outreach and capacity with extension jib	
Length	From 1400 mm to 2000 mm
Capacity	from 450 kg to 250 kg