

CRANE GZ1000BP

LIFTING CAPACITY 1000 KG

COUNTERBALANCED CRANE WITH RIGID ARM ELECTRIC LIFT AT SINGLE SPEED AND ELECTRIC LOWER AT ADJUSTABLE SPEED



Model		GZ1000BP
Drive		Manual
Rotation		Rigid arm
Arm lifting		Electric – push button pendant station
Arm lowering		Electric – push button pendant station
Arm extension		Manual - lockable in 4 positions
Width	mm/inch.	800 / 31
Max capacity with standard arm	Kg / lbs.	1000 / 2204 * see load chart below
Max capacity with extension PZF_MBP	Kg / lbs.	450 / 992 * see load chart below
Weight of the crane (counterweight incl.)	Kg / lbs.	1190 / 2623
Battery type		Lead acid
Batteries nos.	pcs	1
Battery voltage / nominal capacity	V / Ah	12 / 80
Lifting motor	W	-
Traction motor	W	-

CRANE GZ1000BP MAIN DIMENSIONS

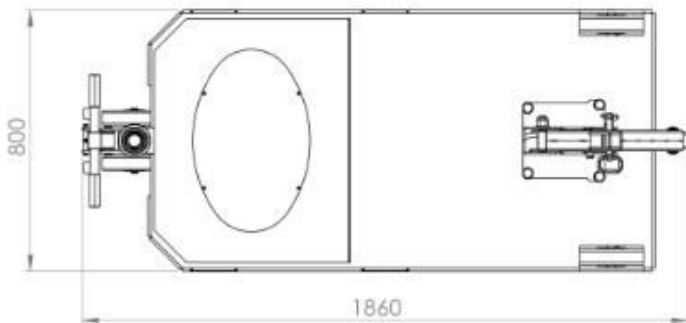
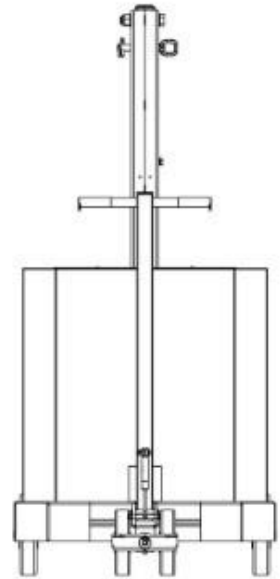
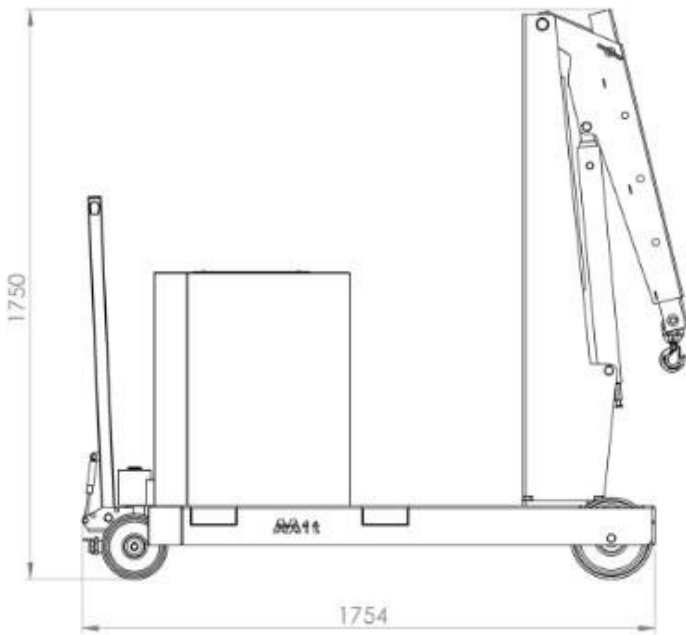

CRANE GZ1000BP DETAILED DIMENSIONS WITH STANDARD ARM

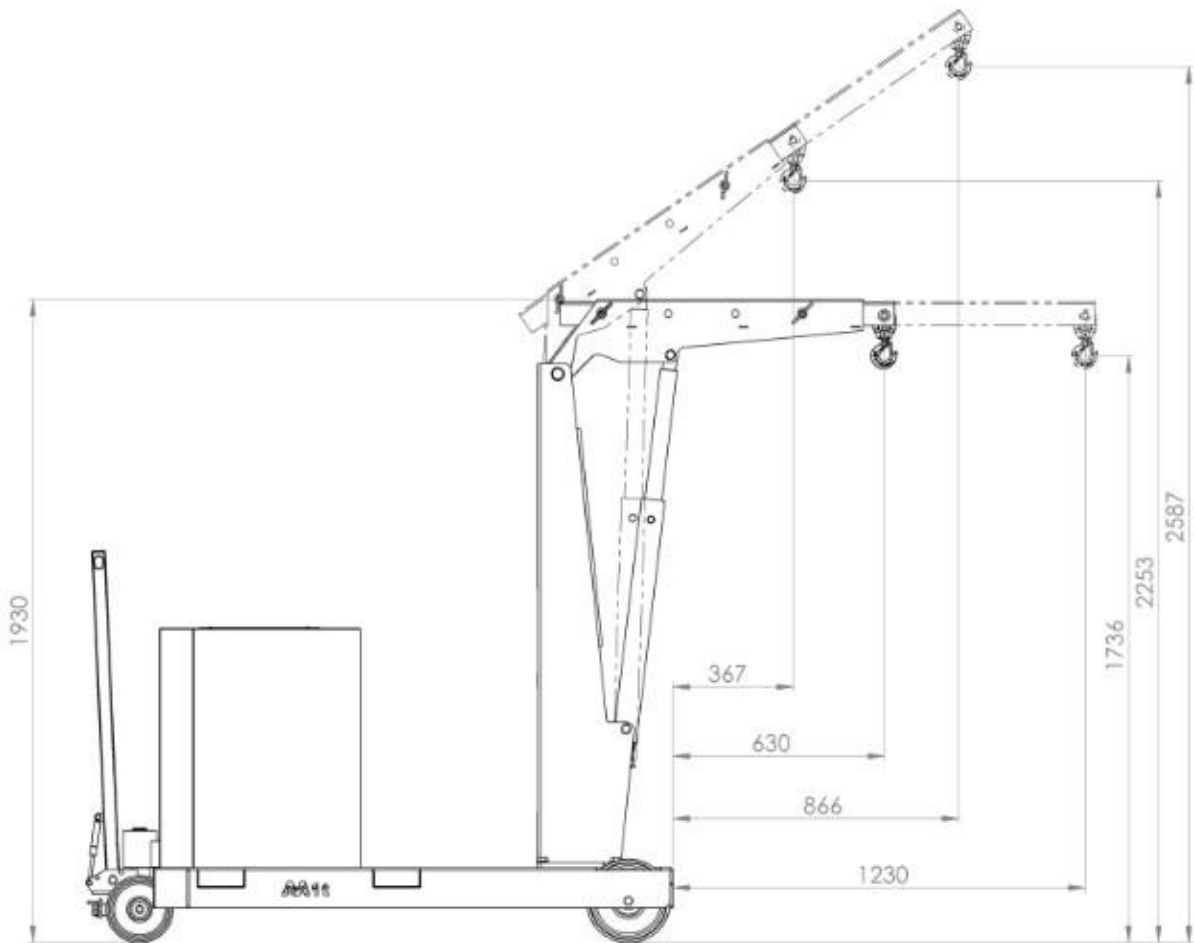

CRANE GZ1000BP

LOAD CHART WITH STANDARD ARM

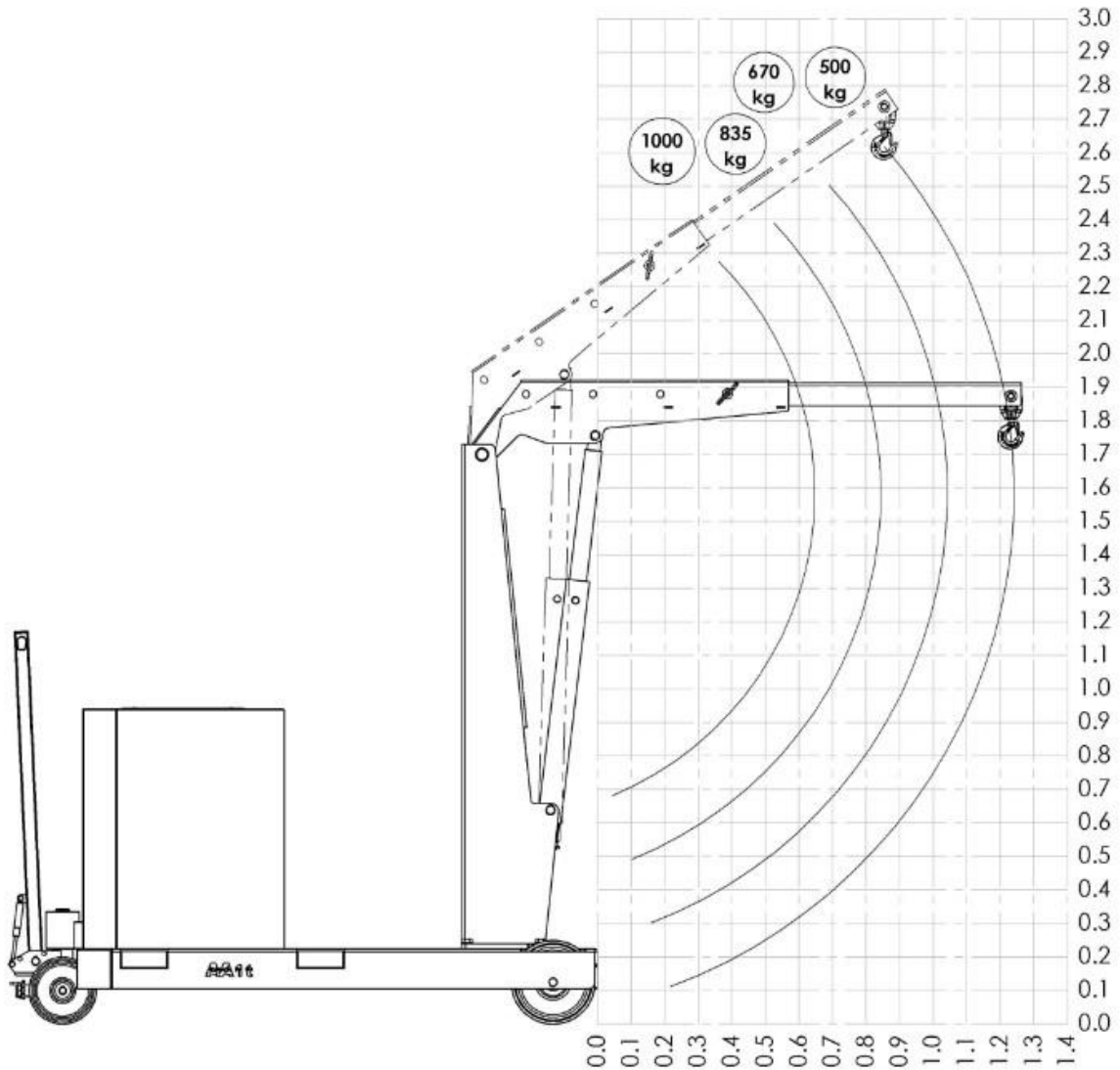

POS.	OVERHANG MM / INCH.	CAPACITY KG / LBS.
1	650 / 25	1000 / 2204
2	850 / 33	835 / 1840
3	1050 / 41	670 / 1477
4	1250 / 49	500 / 1102

CRANE GZ1000BP

LOAD CHART WITH OPTIONAL EXTENSION PZF_MBP

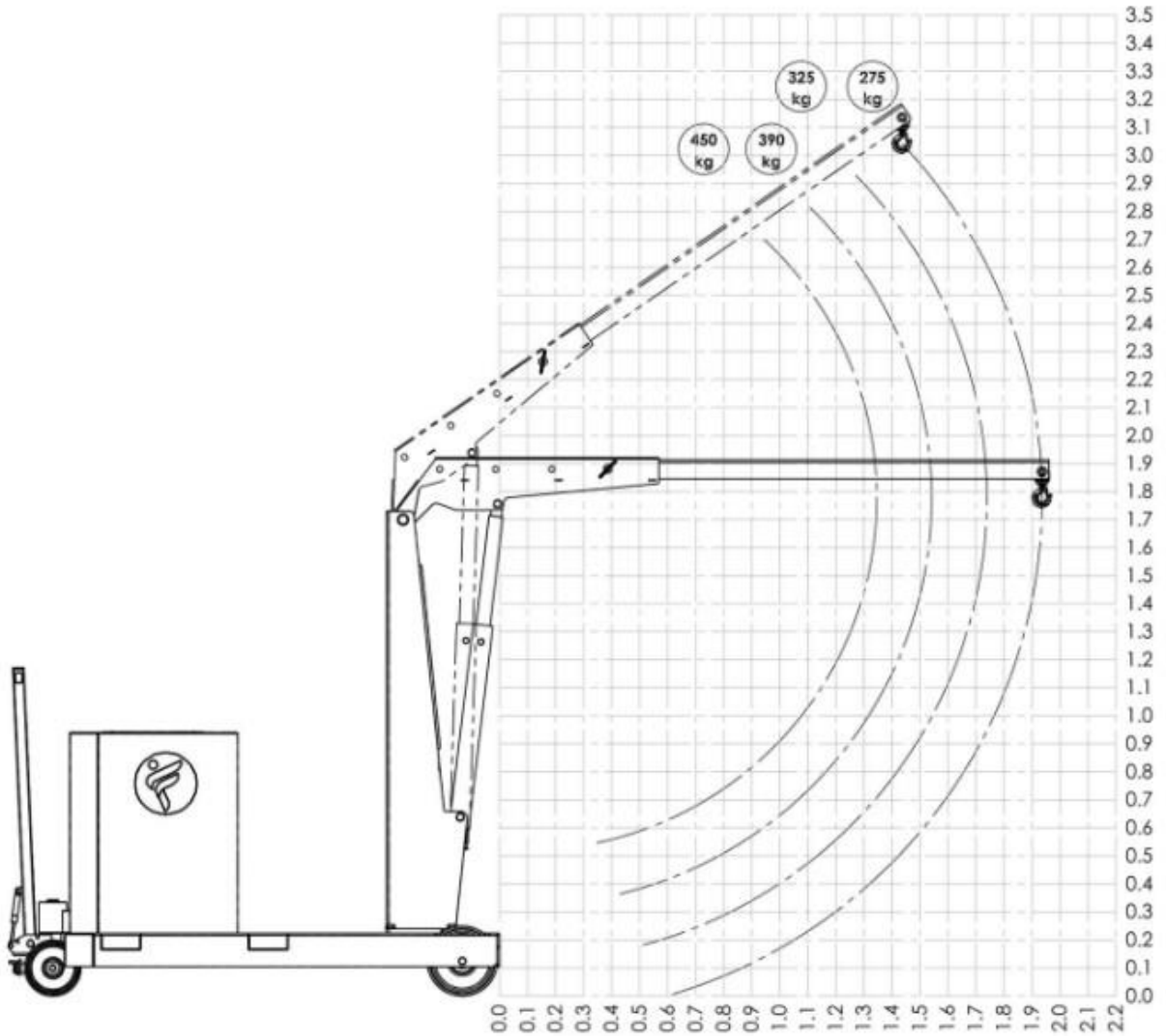

POS.	OVERHANG MM / INCH.	CAPACITY KG / LBS.
1	1400 / 55	450 / 992
2	1600 / 63	390 / 859
3	1800 / 70	325 / 716
4	2000 / 78	275 / 606