

CRANE GZ1000B

LIFTING CAPACITY 1000 KG
COUNTERBALANCED CRANE WITH RIGID ARM
ELECTRIC LIFT & LOWER AT SINGLE SPEED



Model		GZ1000B
Drive		Manual
Rotation		Rigid arm
Arm lifting		Electric – push button pendant station
Arm lowering		Electric – push button pendant station
Arm extension		Manual – lockable in 4 positions
Width	mm/inch.	800 / 31
Max capacity with standard arm	Kg / lbs.	1000 / 2204 * see load chart below
Max capacity with extension PZF_MBP	Kg / lbs.	450 / 992 * see load chart below
Weight of the crane (counterweight incl.)	Kg / lbs.	1190 / 2623
Battery type		Lead acid
Batteries nos.	pcs	1
Battery voltage / nominal capacity	V / Ah	12 / 80
Lifting motor	W	-
Traction motor	W	-

CRANE GZ1000B MAIN DIMENSIONS

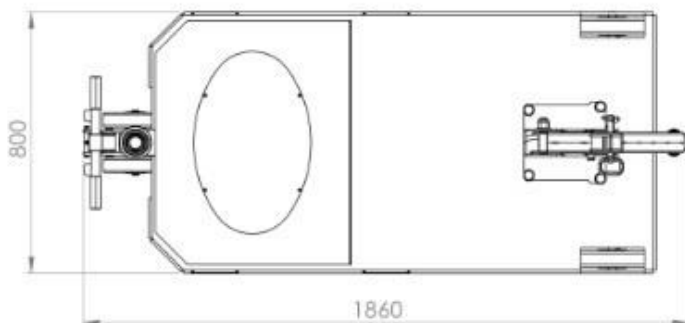
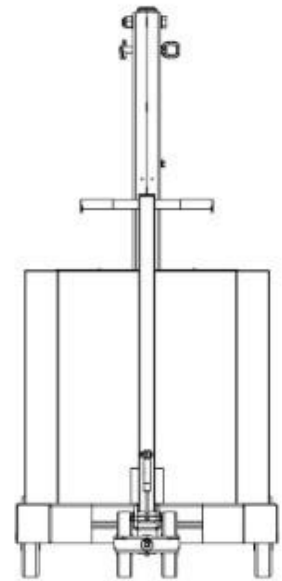
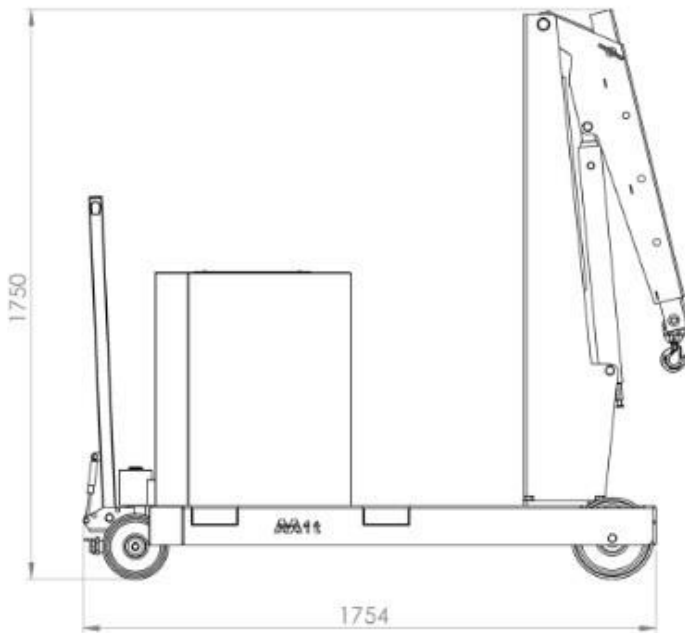

CRANE GZ1000B DETAILED DIMENSIONS WITH STANDARD ARM

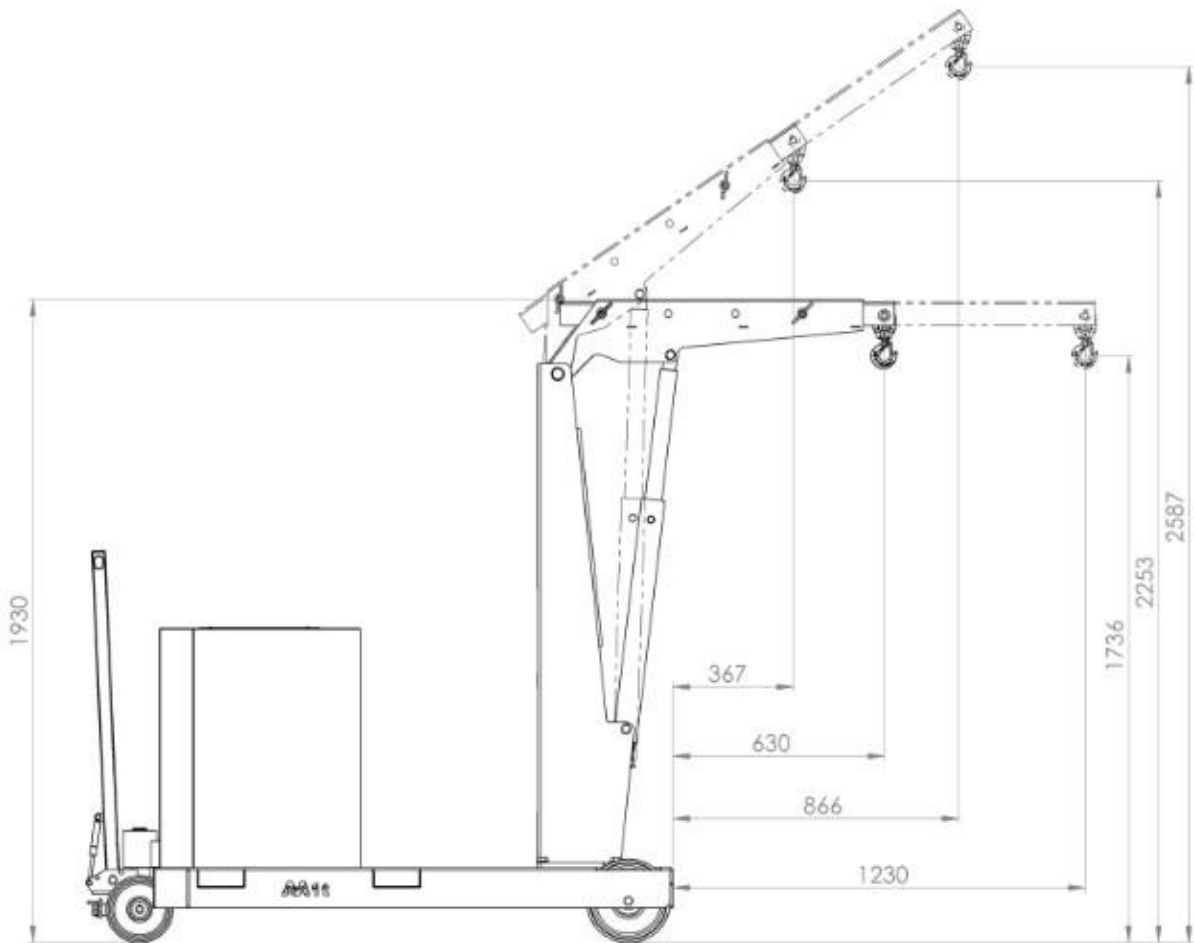

CRANE GZ1000B

LOAD CHART WITH STANDARD ARM

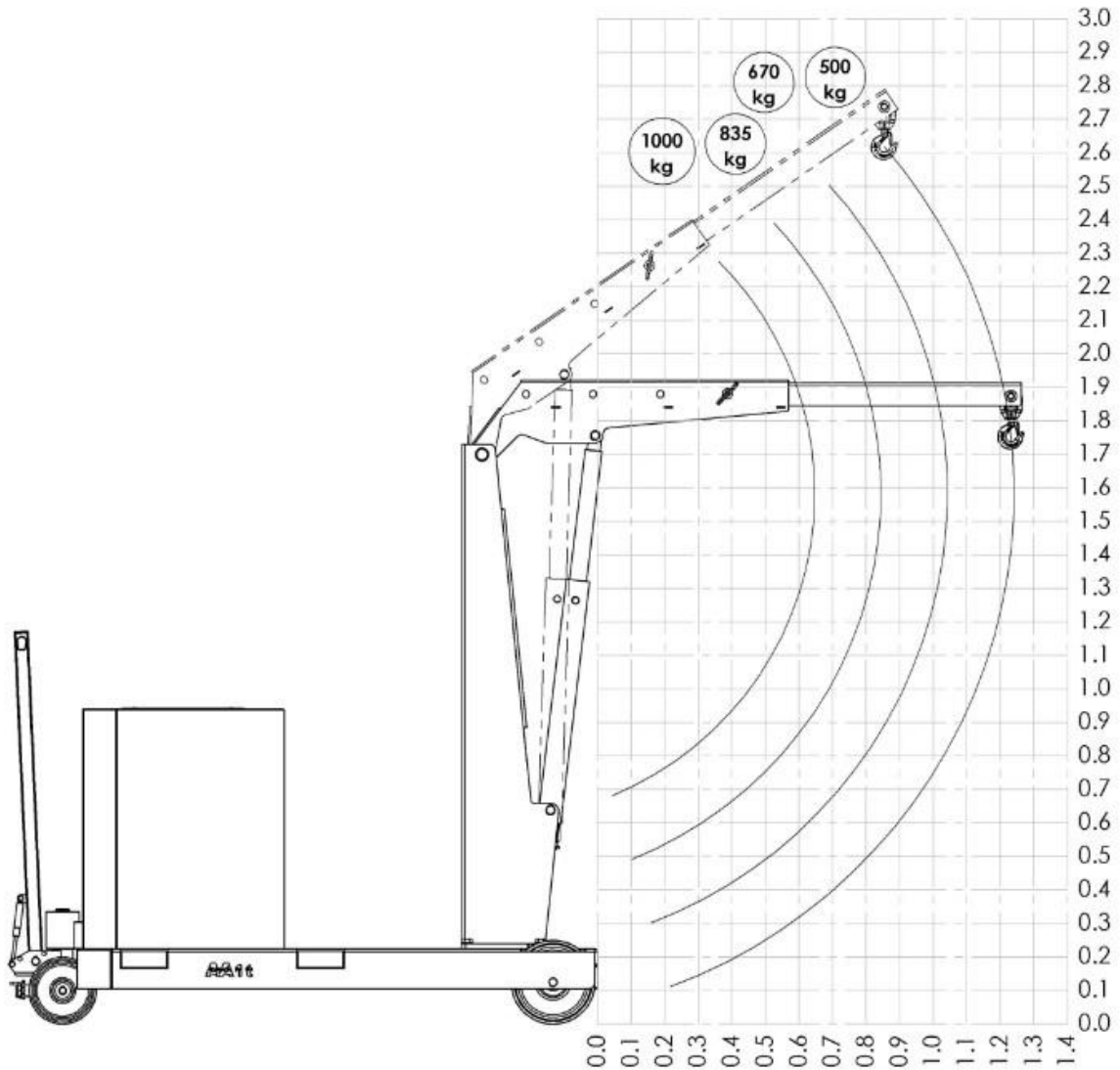

POS.	OVERHANG MM / INCH.	CAPACITY KG / LBS.
1	650 / 25	1000 / 2204
2	850 / 33	835 / 1840
3	1050 / 41	670 / 1477
4	1250 / 49	500 / 1102

CRANE GZ1000B

LOAD CHART WITH OPTIONAL EXTENSION PZF_MBP

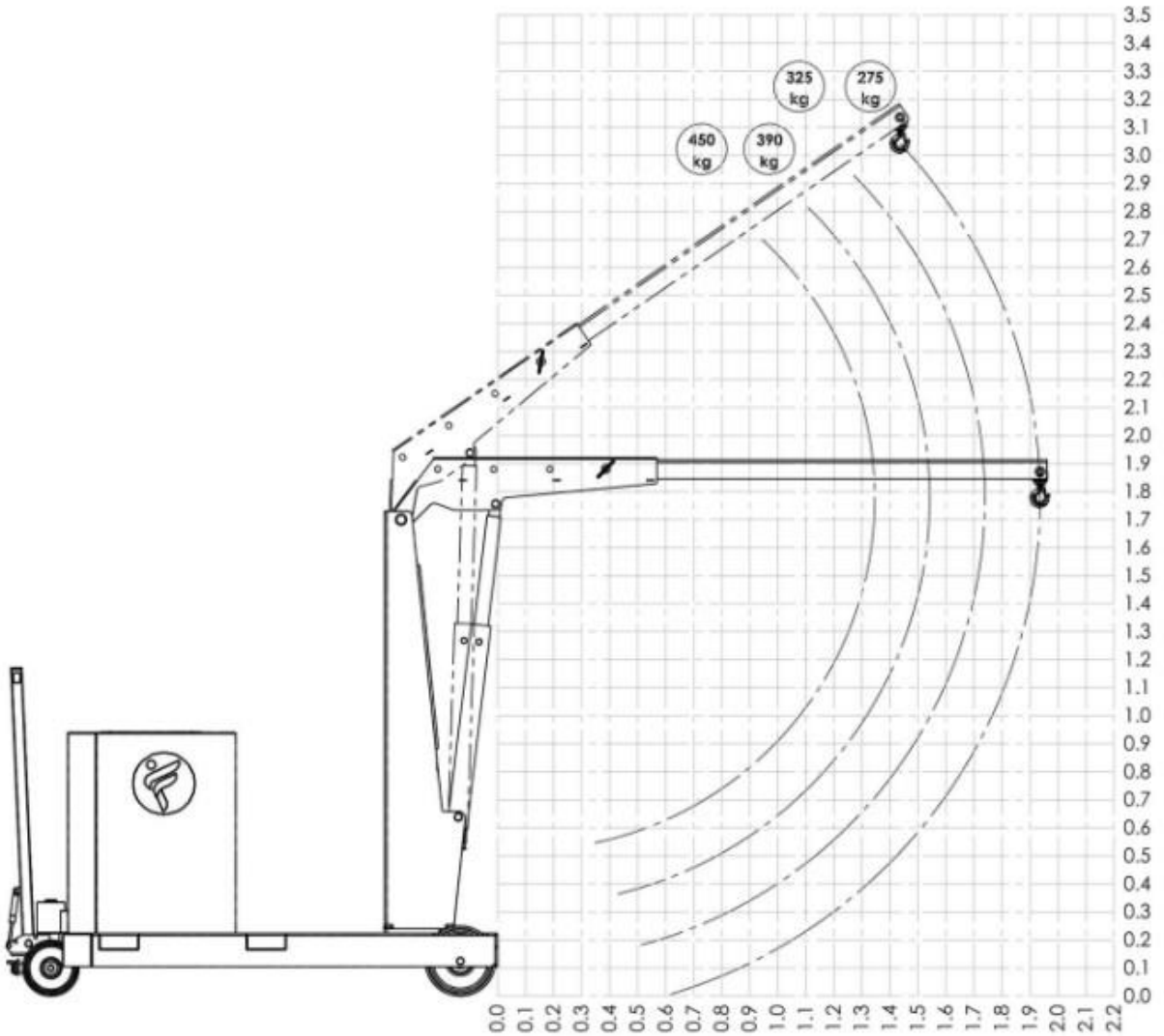

POS.	OVERHANG MM / INCH.	CAPACITY KG / LBS.
1	1400 / 55	450 / 992
2	1600 / 63	390 / 859
3	1800 / 70	325 / 716
4	2000 / 78	275 / 606