

CRANE 01B5P

LIFTING CAPACITY 500 KG
COUNTERBALANCED SWIVEL CRANE ELECTRIC LIFT AT SINGLE SPEED AND ELECTRIC
LOWER AT ADJUSTABLE SPEED



Model		01B5P
Drive		Manual
Rotation		360° manual - slewing bearing system
Arm lifting		Electric – push button pendant station
Arm lowering		Electric – push button pendant station
Arm extension		Manual – lockable in 4 positions
Width with arm not rotated	mm/inch.	980 / 38
Width with arm rotated at 90°	mm/inch.	1140 / 44
Max capacity with standard arm	Kg / lbs.	500 / 1102 * see load chart below
Max capacity with extension PZG1_MBP	Kg / lbs.	250 / 551 * see load chart below
Max capacity with extension PZG2_MBP	Kg / lbs.	205 / 452 * see load chart below
Max capacity with extension PZG3_MBP	Kg / lbs.	160 / 353 * see load chart below
Weight of the crane (counterweight incl.)	Kg / lbs.	640 / 1410
Battery type standard		Lead acid
Batteries nos.	pcs	1
Battery voltage / nominal capacity	V / Ah	12 / 80
Lifting motor	W	-
Traction motor	W	-

CRANE 01B5P MAIN DIMENSIONS

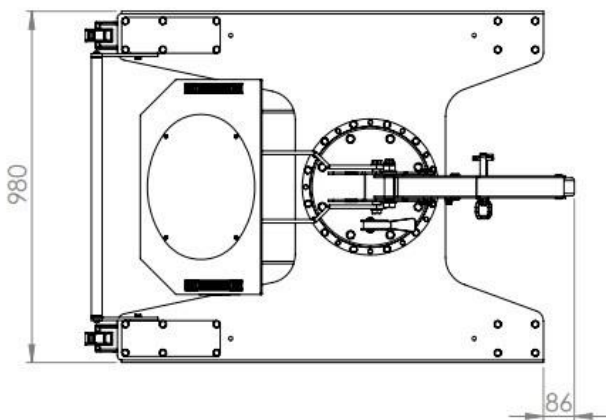
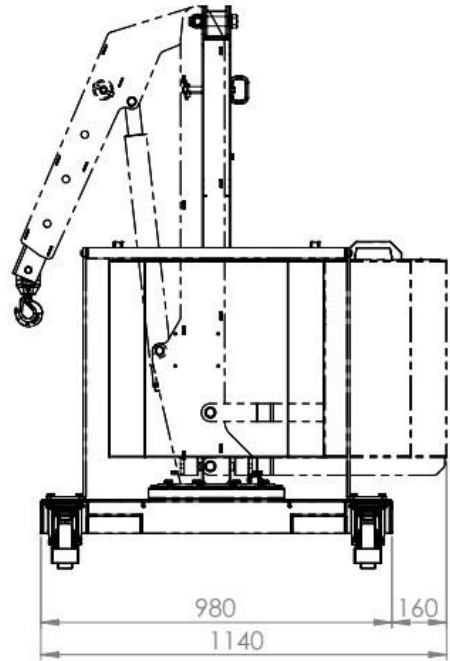
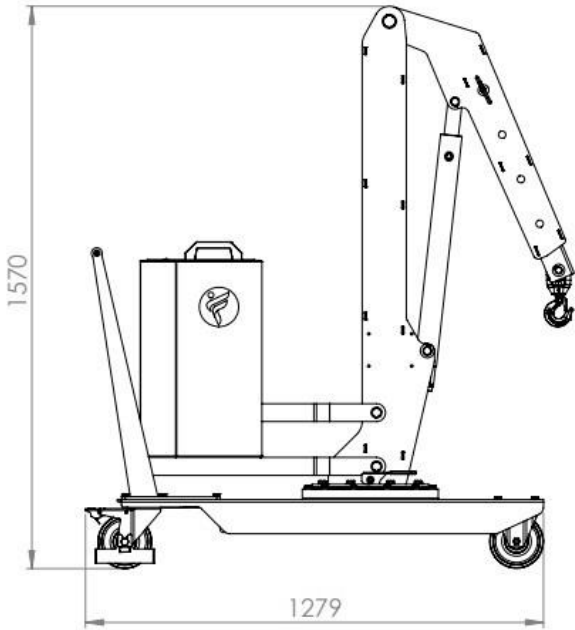

CRANE 01B5P DETAILED DIMENSIONS WITH STANDARD ARM

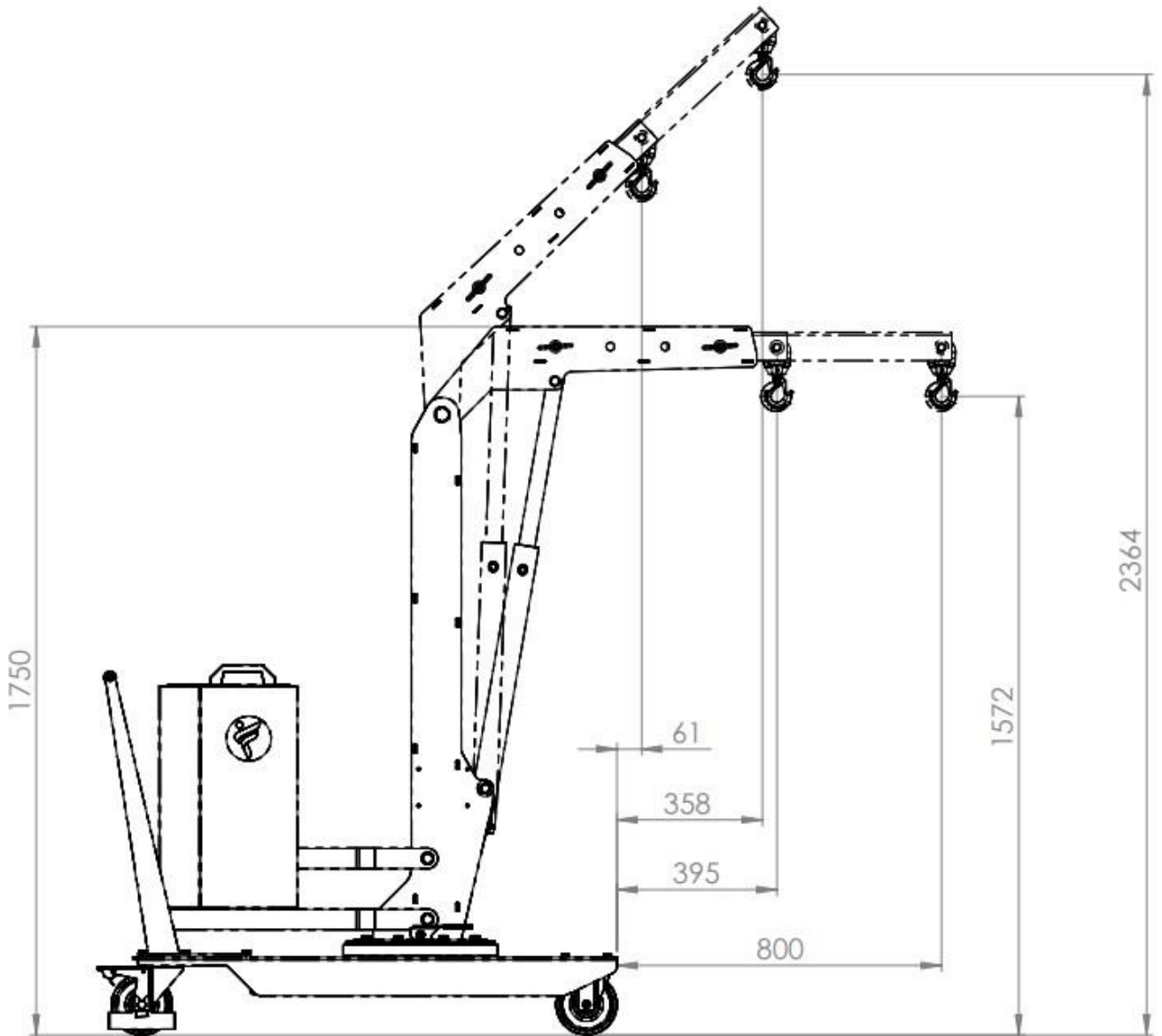

CRANE 01B5P MAIN DIMENSIONS

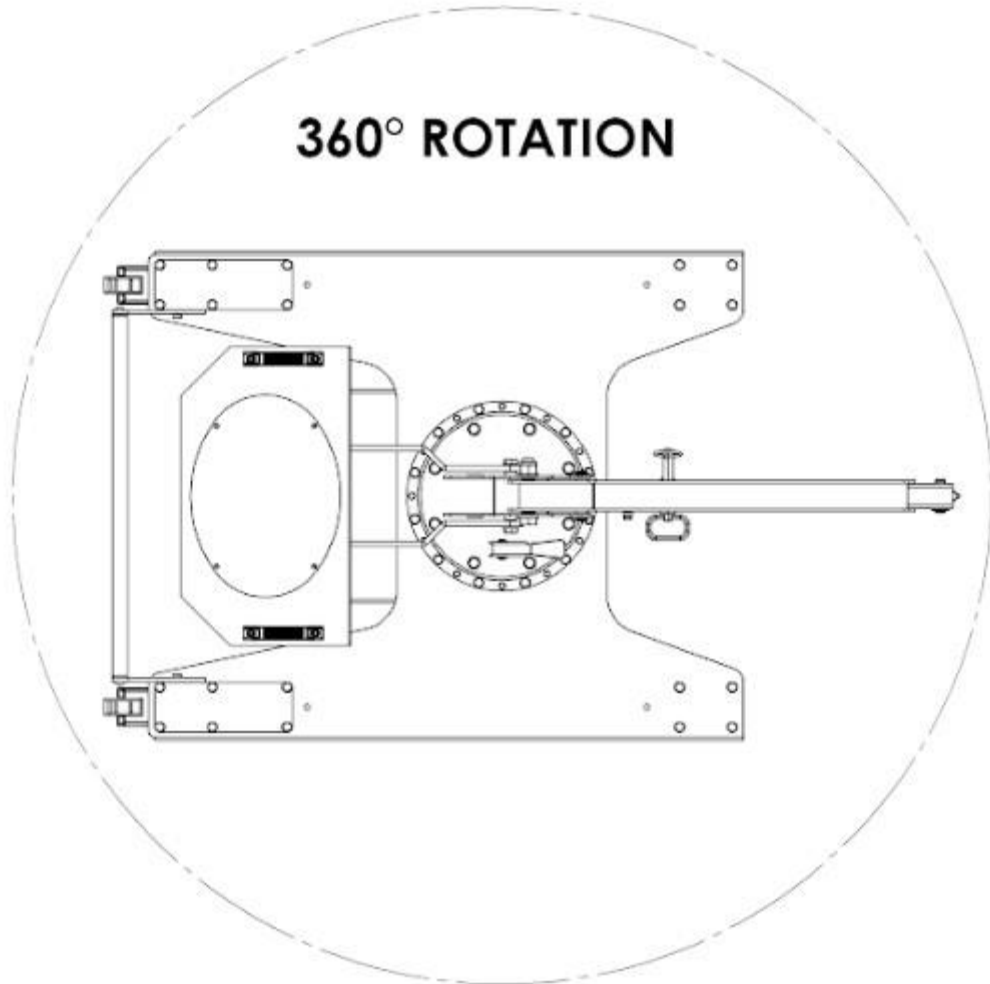

CRANE 01B5P LOAD CHART WITH STANDARD ARM

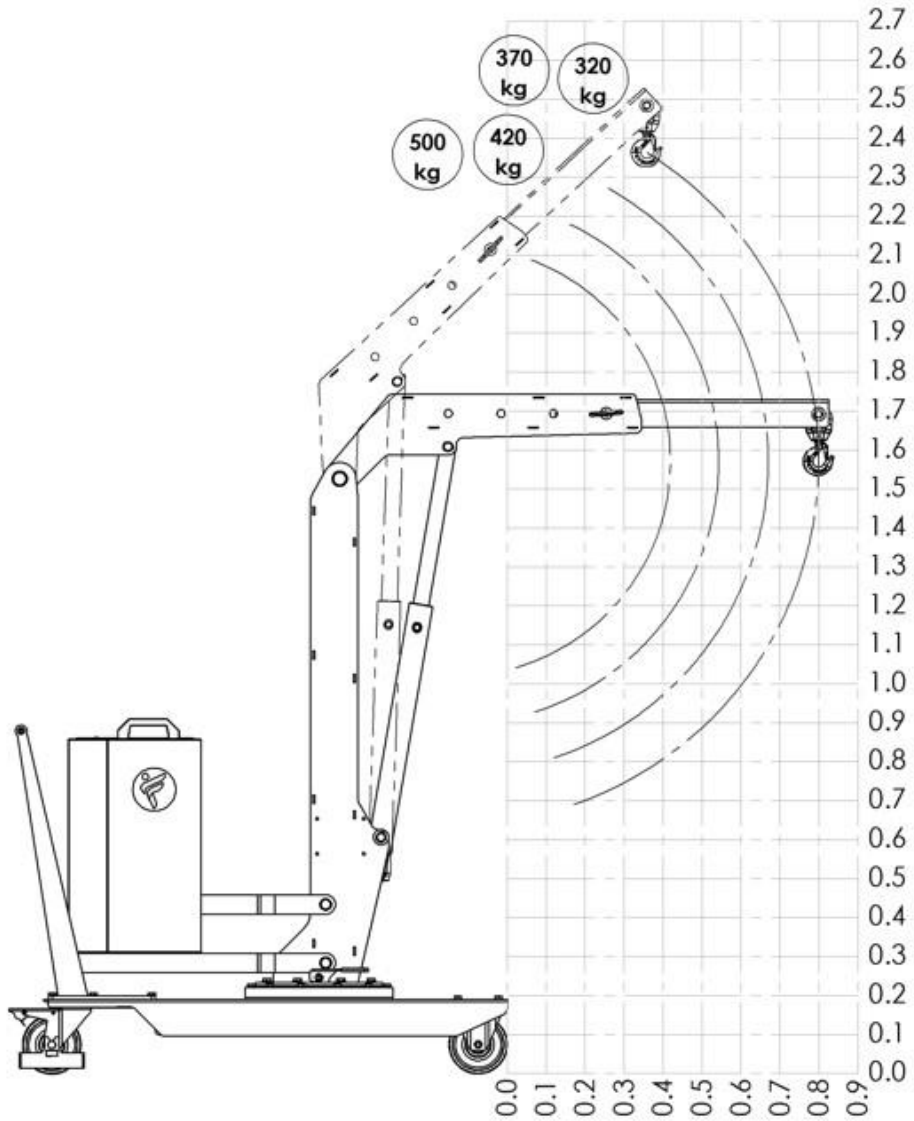

POS.	OVERHANG MM / INCH.	CAPACITY KG / LBS.
1	365 / 14	500 / 1102
2	500 / 20	420 / 926
3	635 / 25	370 / 816
4	770 / 30	320 / 705

CRANE 01B5P LOAD CHART WITH OPTIONAL EXTENSION PZG1-MBP

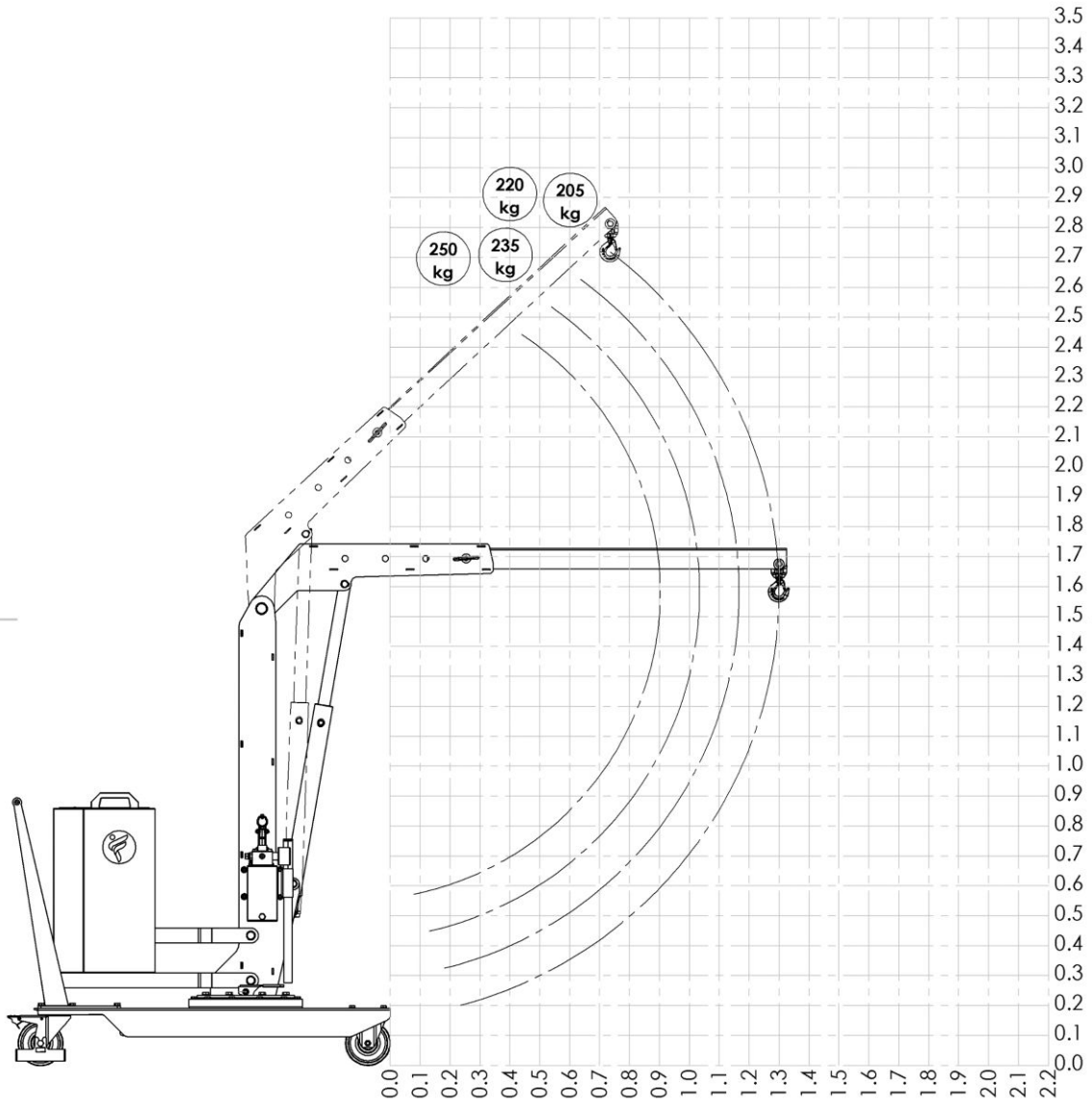

POS.	OVERHANG MM / INCH.	CAPACITY KG / LBS.
1	865 / 34	250 / 551
2	1000 / 39	235 / 518
3	1135 / 45	220 / 485
4	1270 / 50	205 / 452

CRANE 01B5P LOAD CHART WITH OPTIONAL EXTENSION PZG2-MBP

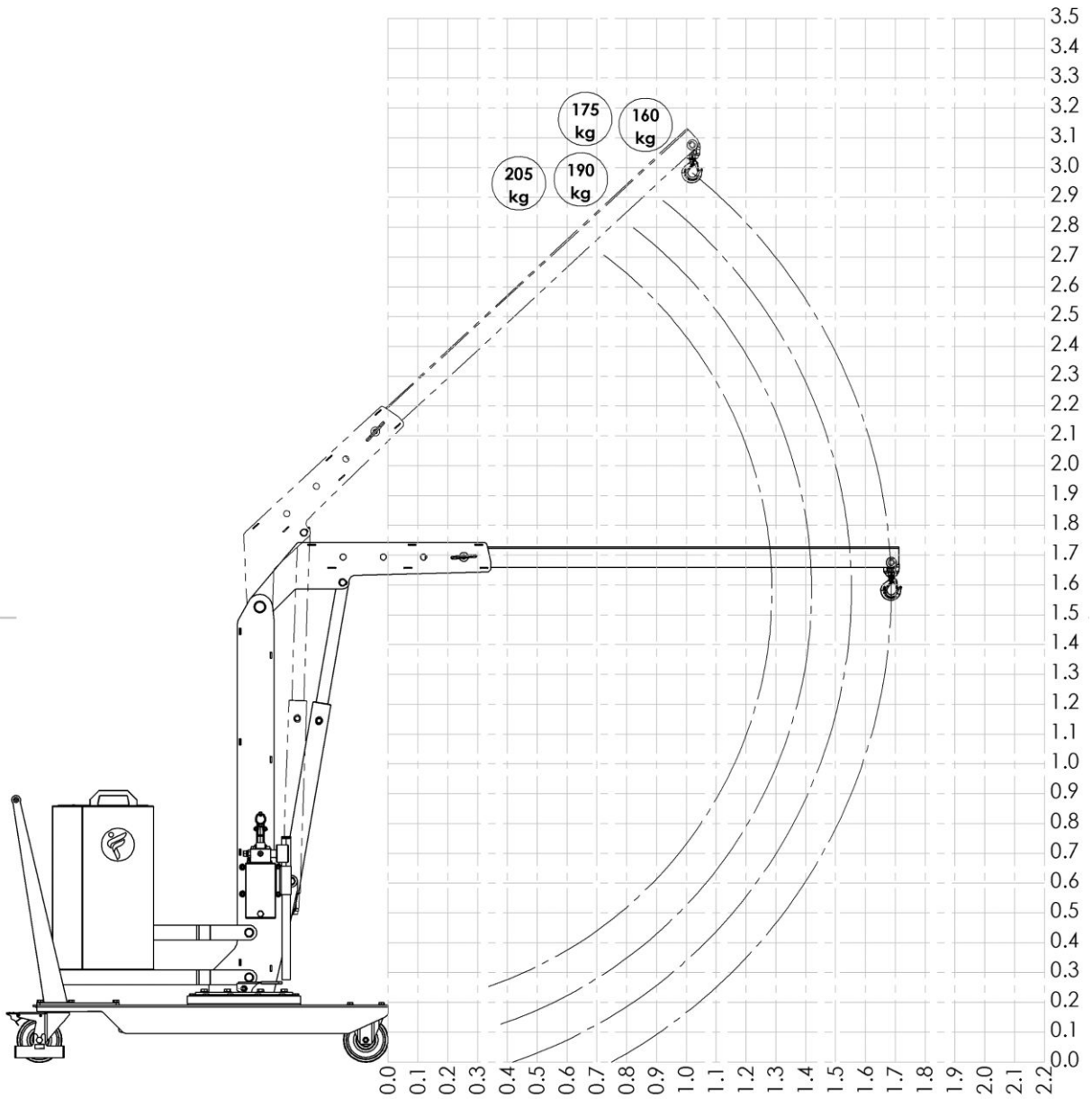

POS.	OVERHANG MM / INCH.	CAPACITY KG / LBS.
1	1250 / 49	205 / 452
2	1385 / 54	190 / 418
3	1520 / 60	175 / 385
4	1655 / 65	160 / 352

CRANE 01B5P LOAD CHART WITH OPTIONAL EXTENSION PZG3-MBP

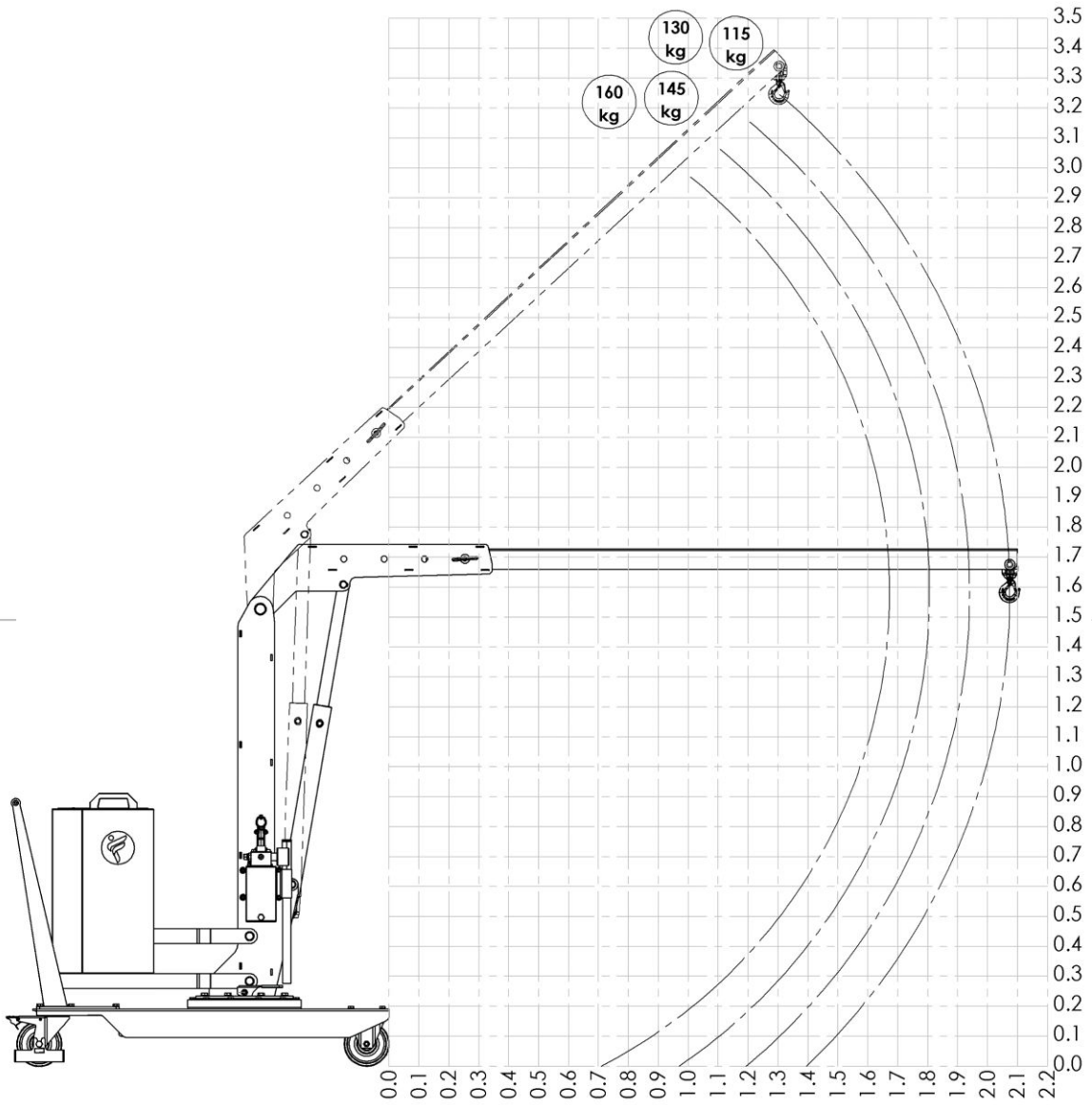

POS.	OVERHANG MM / INCH.	CAPACITY KG / LBS.
1	1645 / 65	160 / 352
2	1780 / 70	145 / 319
3	1915 / 75	130 / 286
4	2050 / 81	115 / 253