



01B2SE

360° pivoting arm

4 -function distributor

Capacity
200 kg

BUILT-IN BALLAST WEIGHTS



Mod. 01B2SE is a counterbalanced floor crane to lift loads up to 200 kg. Ideal for awkward placements from the ground onto 3D machines, lathes, over perimeter protections, narrow openings, etc., thanks to its 360° pivoting arm.

It is equipped with a 4-function electric distributor for arm lifting, lowering jib extension and retraction. All functions are activated by a built-in lever. Lowering occurs in off-mode.

It comes with two safety valves to prevent falling of loads in the event of hose failure and to prevent machine overloading.



01B2SE

Extremely precise placement with infinite adjustment speed

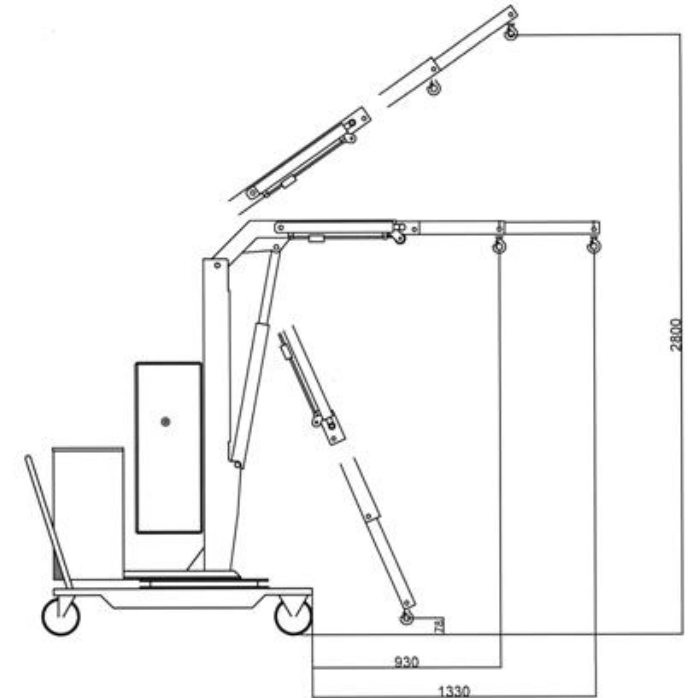
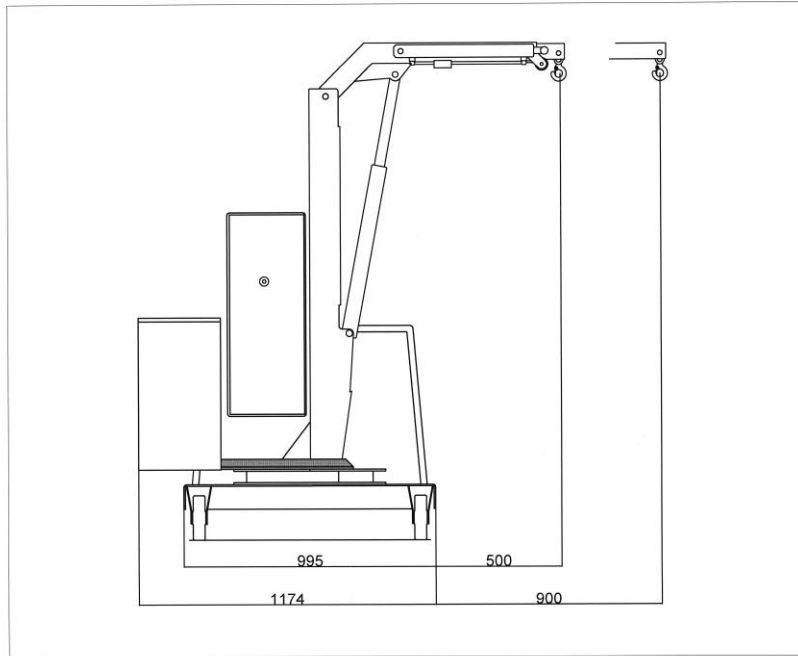

Technical data

Weight	[kg]	410
Max capacity	[kg]	200
Max pressure	[BAR]	100
Battery	[V]	12
	[A]	80
Power	[W]	300
Tank capacity	[L]	1,5

Cylinder

Stroke	∅	∅ Stem
[mm]	[mm]	[mm]
470	60	40

All components are made in Italy

Standard jib outreach and capacity

Length	From 485 mm to 885 mm
Capacity	From 200 kg to 130 kg

Optional extension jib outreach and capacity

Length	From 930 mm to 1330 mm
Capacity	From 92 kg to 71 kg

This crane allows to carry out placements in full compliance with Health and Safety norms.

Suitable to operate in tiny spaces thanks to its small frontal size (995mm)

