



01B2
01B2P

**Conterbalanced
Electric
Swivel Crane**

Capacity 200 kg



Mod.**01B2** is an extremely versatile, easy to operate crane.

Suitable for lifting loads of various shapes and dimensions from the ground to machines, assembly lines, shelves, etc.

Ideal to place moulds, spare parts and various products on machine tools with perimeter protections or narrow openings (presses, lathes, milling machines)

Single speed



Progressive speed

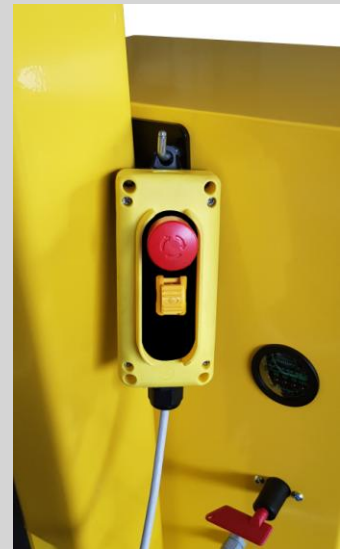



01B2 01B2P

Mod.01B2/01B2P is equipped with a push-buttons board for electric lifting and lowering

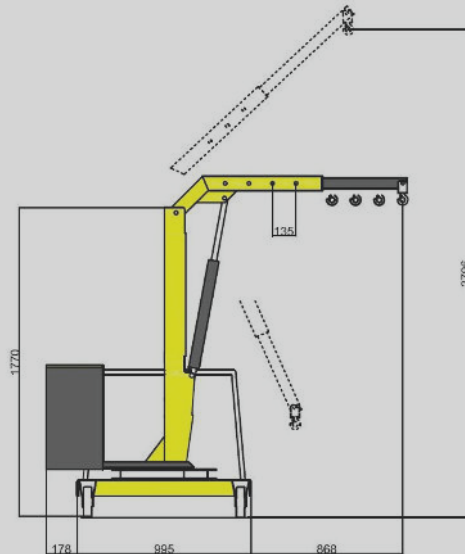
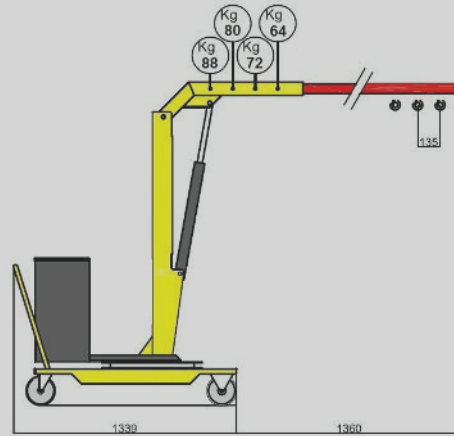
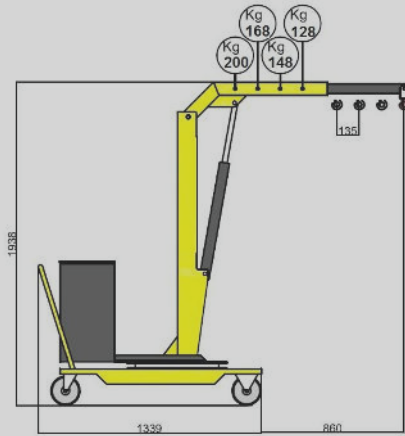

Technical data

Weight	[kg]	400
Max cap.	[kg]	200
Max lifting time	[sec]	17
Max lowering time	[sec]	25
Max pressure	[BAR]	100
Battery	[V]	12
	[A]	80
Power	[W]	300
Tank cap.	[L]	1,5

Cylinder

Stroke	∅	∅ Stem
[mm]	[mm]	[mm]
500	60	30

Mod.01B2 /01B2P comes with a revolving jib extendible in 4 positions

The cylinder has a burst valve that forbids the falling of load in the event of hose failure. The pump is equipped with a pressure relief valve that prevents operating above maximum capacity. Lowering speed can be regulated by means of a valve which is mounted underneath the cylinder. Extension jib is also available on demand to increase outreach up to 1360 mm

Inspections by Board of certification is not required for Mod.01B2/01B2P (max cap.200 kg)

Outreach with standard jib

Pos.	Length [mm]	Capacity [kg]
1	455	200
2	590	168
3	725	148
4	860	128

Outreach with extension jib

Pos.	Length [mm]	Capacity [kg]
1	955	88
2	1090	80
3	1225	72
4	1360	64