

**PICK & CARRY CRANE
FULL ELECTRIC POWERED
2 TONS**

**OMNIA 2TL (LEVER PROPORTIONAL CONTROLLED)
OMNIA 2TR (PROPORTIONAL REMOTE CONTROLLED)
CAPACITY 2000KG WITH TRIPLE ELECTRIC BOOM**



Models OMNIA 2TL and 2TR are a full electric powered Pick & Carry crane with a maximum capacity of 2000 Kg and with a triple electric boom that can reach a free overhang of more than 3 meters.

One of the key features of this pick and carry crane is that there are no lateral outriggers, therefore this crane grants max mobility with suspended load.

The OMNIA is the ideal crane for lifting heavy and bulky loads and thanks to its extreme maneuverability it can reach any location where the load has to be picked up, including narrow aisles and tunnels. It has an excellent steering angle that allows it to move along the narrow spaces or rotate on its axis in limited spaces. It is equipped with AGM batteries that can be recharged in areas with limited ventilation.

OMNIA is a full electric crane that can be used in all sectors being silent, environmentally friendly and zero-emission. In line with Health and Safety international standards (emergency buttons, warning devices, relief and check valves).

It is equipped with a maximum load dynamic throttling device , which prevents the crane from loading beyond maximum range at each point of the slide by inhibiting the ascent and feed controls until the operator re-enter the load within the permitted limits.

It can be equipped with any type of under hook accessory (vacuum lifter, bars, beans, clamps, tilters, permanent magnets and customised solutions) for unlimited applications in a large variety of industries.

Technical data	UM	OMNIA 2TL/2TR
Weight	[kg]	1900
Max capacity	[kg]	2000
Lifting motor	[W]	3000
Traction motor	[W]	1200
Tank capacity	[L]	4

Traction and controller			
2 AGM airtight batteries		1 battery charger	
[V]	[A]	[V]	[A]
2 x 12	2 x 260	24	12

OMNIA 2TL / OMNIA 2TR

CAPACITY 2000 KG

LOADING CHART

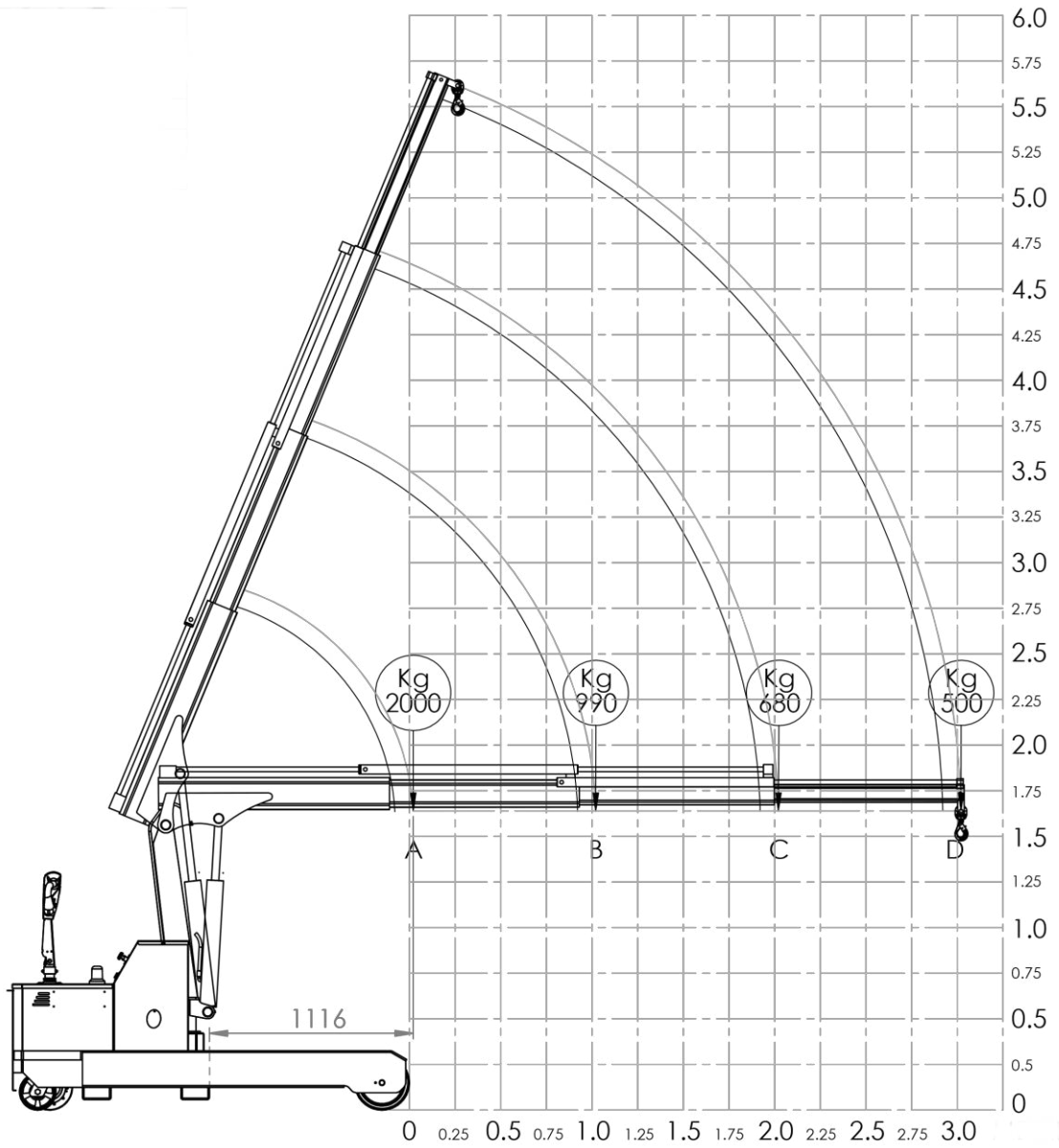

OMNIA 2TL / OMNIA 2TR

CAPACITY 2000 KG WITH TRIPLE ELECTRIC BOOM

TILLER ARM

Maximum ergonomics : the operator can firmly grip the tiller handles with both hands

Safe driving : Tiller arm safety switch disables operation in non-allowed positions

Slow/fast speed : 2-speed driving

Slow mode of 1.5 km/hr ideal for tight spaces and to safely move the load

Standard speed of 3.0 km/hr to drive the crane along long distances

Audible motion warning device : Horn with anti-noise polyester axial capacitor

Anti-crush belly button: anti-crush button with automatic reversing switch to ensure the safety of the operator during operation

2 butterfly controls: for forward travel and backward travel controls



CONTROLS, WARNING LIGHTS AND STANDARD FEATURES

2 position **key switch** ; **emergency button** ; Indicator showing the **battery charge level**; **Schuko socket** for 220V charge ; Visual warning **LED beacon**; 24V **intermittent buzzer** when the crane is moving to increase operator safety; **Storage compartment**.

OMNIA 2TL is equipped with proportional control levers with adjustable speed

It is equipped with proportional control levers as follows :

- 1) Lever that controls the jib upward/downward motion
- 2) Lever that controls the jib extension & retraction

OMNIA 2TR is equipped with remote control with proportional and adjustable speed . The remote control handle is equipped with a button , that allows you to activate the proportional control mode.

- 1) Lever that controls the jib upward/downward motion
- 2) Lever that controls the jib extension & retraction



BUILT-IN CHARGER

Pulse model with single phase 220V high frequency input voltage and 24V output voltage.

Microprocessor indicator with relay for lifting block. **3 LEDs** that indicate the operating status. **Remote RBC indicator** for displaying the charging phase of the battery charger.



DYNAMIC LOAD LIMITER

System for preventing overloading in each position of the extension that activates a mechanism that blocks the upward and extension motion ensuring the functionality of the crane in absolute safety and that signals when the crane returns to allowed position, re-enabling the controls.



POWER DRIVE

AC traction motor with recovery braking. Permanent magnet **drive wheel** in direct current 24V 700W; high frequency **MOSFET controller**.



OMNIA 2TL / OMNIA 2TR
TECHNICAL DRAWINGS, DIMENSIONS AND CAPACITIES
Extreme precision in all movements

